

JOURNAL OF **SWINE HEALTH & PRODUCTION**

Effect of Zn supplement on sow claw
quality

van Riet MMJ, Bos EJ, Ampe B, et al

Digital images evaluating nursery
pig behavior post injection

Weimer SL, Fangman TJ, Karriker LA, et al

Serum and milk antibody responses in
PEDV-immune gilts post vaccination

*Bjustrom-Kraft J, Woodard K,
Giménez-Lirola L, et al*

Antibody evidence of PRRSV
in feral swine

Pedersen K, Miller RS, Musante AR, et al



Journal of Swine Health and Production

(ISSN 1537-209X) Volume 26, Number 1; January and February 2018
Copyright © 2018 American Association of Swine Veterinarians



The *Journal of Swine Health and Production* is published by the American Association of Swine Veterinarians.

Opinions expressed in this publication are those of the individual authors and do not necessarily reflect the endorsement, official attitude, or position of the American Association of Swine Veterinarians, the *Journal of Swine Health and Production*, or any Industry Support Council member.

The *Journal of Swine Health and Production* is a refereed publication and is a benefit of membership in the American Association of Swine Veterinarians. Subscriptions (\$US) are available to nonmembers at \$145.00 per year (six issues) for United States, Canada, and Mexico. The cost is \$180.00 for all countries outside North America. For inquiries regarding membership or subscriptions, please contact

AASV
830 26th Street, Perry, IA 50220-2328
Tel: 515-465-5255; Fax: 515-465-3832
E-mail: aasv@aasv.org

Editorial questions, comments, and inquiries should be addressed to Karen Richardson, Publications Manager:
Tel: 519-856-2089;
E-mail: jshap@aasv.org

DISCLAIMER

Scientific manuscripts published in the *Journal of Swine Health and Production* are peer reviewed. However, information on medications, feed, and management techniques may be specific to the research or commercial situation presented in the manuscript. It is the responsibility of the reader to use information responsibly and in accordance with the rules and regulations governing research or the practice of veterinary medicine in their country or region.

AASV Officers

ALEX RAMIREZ
President,
ramireza@iastate.edu

SCANLON DANIELS
President-elect,
scanlon@circleh.info

AASV Staff

TOM BURKGREN
Executive Director,
burkgren@aasv.org

SUE SCHULTEIS
Associate Director,
aasv@aasv.org

JSHAP Staff

TERRI O'SULLIVAN
Executive Editor, jshap@aasv.org

JUDI BELL
Associate Editor, jshap@aasv.org

KAREN RICHARDSON
Publications Manager, jshap@aasv.org

TINA SMITH
Graphic Designer, Advertising Coordinator,
tina@aasv.org

Editorial Board

GLEN ALMOND
North Carolina, glen_almond@ncsu.edu

JANE CHRISTOPHER-HENNINGS
South Dakota, Jane.Hennings@sdstate.edu

PHIL GAUGER
Iowa, pcgauger@iastate.edu

JOHN HARDING
Saskatchewan, john.harding@usask.ca

JAMES KOBER
Michigan, svsmi@4starvets.com

ADAM MOESER
Michigan, moeserad@cvm.msu.edu

NATHAN WINKELMAN
Vice President,
nwink@swineservices.org

GEORGE CHARBONNEAU
Immediate Past President,
gcharbonneau@southwestvets.ca

HARRY SNELSON
Director of Communications,
snelson@aasv.org

DAVE BROWN
Webmaster/IT Specialist,
dave@aasv.org

LAURA BATISTA AND SANDRA PÉREZ
Spanish translators

SERGE MESSIER
French translator

ZVONIMIR POLJAK
Consulting Epidemiologist

THOMAS PARSONS
Pennsylvania, thd@vet.upenn.edu

ANDRES PEREZ
Minnesota, aperez@umn.edu

ALEX RAMIREZ
Iowa, ramireza@iastate.edu

YOLANDE SEDDON
Saskatchewan, yolande.seddon@usask.ca

MIKE TOKACH
Kansas, mtokach@ksu.edu

BETH YOUNG
Sweden, byoung.dvm@gmail.com

Journal of Swine Health and Production is indexed in ISI[®] Focus On: *Veterinary Science & Medicine*,[®] and in *CAB Abstracts*, Euroscience VETLINE on CD-ROM



Download this issue to your iPad or Android tablet at <https://www.aasv.org/shap/issues/v26n1/v26n1jshap.pdf>



About the cover...

Missouri sow
*Photo courtesy of
 Tina Smith*

AASV Resources online at

<https://www.aasv.org>

Author guidelines

<https://www.aasv.org/shap/guidelines.pdf>

Journal of Swine Health and Production

<https://www.aasv.org/shap.html>

Membership information

<https://www.aasv.org/aasv/membership.html>

Subscription information

<http://ecom.aasv.org/journal>

Upcoming meetings

<https://www.aasv.org/meetings>

TABLE OF CONTENTS

President's message5

Executive Director's message7

Associate Editor's message9

Long-term impact of zinc supplementation in sows: Impact on claw quality10
van Riet MMJ, Bos EJ, Ampe B, et al

Nursery pig behavior evaluation pre- and post injection using digital-image methodology25
Weimer SL, Fangman TJ, Karriker LA, et al

Serum and mammary secretion antibody responses in porcine epidemic diarrhea-immune gilts following porcine epidemic diarrhea vaccination34
Bjstrom-Kraft J, Woodard K, Giménez-Lirola L, et al

Conversion tables 40

Antibody evidence of porcine reproductive and respiratory syndrome virus detected in sera collected from feral swine (*Sus scrofa*) across the United States41
Pedersen K, Miller RS, Musante AR, et al

News from the National Pork Board 45

AASV news 47

AASV Foundation news 49

Advocacy in action 55

Vice-Presidential candidate's message 57

Author guidelines 58

Upcoming meetings 59

“Thank you for making me one of the family - I have loved being a part of your lives”

quoted from the Associate Editor's message, page 9

PROMOTE®

Feed Additives



Innovate. Investigate. Invigorate.

The numbers are in your favor with PROMOTE. You can count on PROMOTE® for research-based feed additive solutions. Supported by the vast global network of research from Cargill Animal Nutrition; PROMOTE offers non-medicated products that help you meet your goals – and satisfy our growing world's demand for more protein.

600

RESEARCHERS

16
GLOBAL LABS

5 INNOVATION CENTERS



COME SEE OUR PRESENTATIONS AT THE AASV ANNUAL MEETING.

FEEDPROMOTE.COM | 866-202-9889

AOX™ | CINERGY | DEFUSION® | ENZAE® | FORAGE-MATE® | INTELLA™ | TRASIC™ | VALIDO™



Sorry, I am busy

How often do we hear the excuse “Sorry, I have been busy” or even more dramatic “Sorry I have not replied to your e-mail, I just have been very busy...” We all hear these statements when we are asking someone for input or seeking someone to address an issue or concern. The question is, are they that busy, or is this just an excuse?

If we are to be honest, instead of saying “I don’t have time” say “It is not a priority for me.” This is harder to say but is reality. We all make time for things we want to do. We all find excuses for things we prefer not to do. There are many times when other people’s priorities are not our priority or concern; and that is okay, we just need to be honest. Amazingly, some of the people who are good at replying to e-mails in a timely manner are the same people I would consider extremely busy.

This issue of priority is critical when looking at taking time to address employee concerns, taking time to train or mentor someone, helping serve or promote a cause, or simply taking time to help others. Our association is very grateful to the many who volunteer their time and talents to advance our goals. The talents of many of our members are amazing. It is amazing how unselfish they are in giving and not asking for something in

return. Sometimes it seems like we continue to ask the same people to do more.

Volunteering follows the 90-10 rule. It is 10% of individuals that do all the volunteering. This same 10% volunteer for many organizations and are just as busy as everyone else is, yet they make time.

The same is true for advocacy. It is easy to sit back and complain about new rules or lack of understanding or support of animal agriculture. The question is, how much of a priority are these issues for us? If they are important to us, then we need to make time. When and how we support this advocacy is a personal preference. If timing is not right, we can always look at helping support the cause through financial contributions.

“Next time a student or AASV asks for your time, be ready to answer, “Yes, I am busy, but this is a priority for me.”

Our AASV Foundation is an excellent example of how we can give back not only through volunteering, but also through financial contributions. Student mentorship is something I highly value. I am fortunate to be in an academic institution in which I can more easily provide this mentorship.

As a swine veterinarian, you, too, can help mentor students through summer programs or preceptorships. Yes, it takes time. Yes, we are all busy. However, if we really want to help the future generation of swine veterinarians, we need to make time. We need to make it a priority. One can also provide financial support to the AASV Foundation so that even when we are not busy mentoring students, students have the opportunity to be mentored by others. These travel stipends to both our annual meeting and for summer preceptorships are invaluable.

Next time a student or AASV asks for your time, be ready to answer, “Yes, I am busy, but this is a priority for me.”

Alex Ramirez, DVM
AASV President





PharmGate Animal Health

Your partner for optimal health and productivity.

NEW

Swine Vaccines

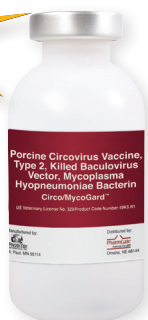

Circo/MycoGard™
circovirus + *Mycoplasma*

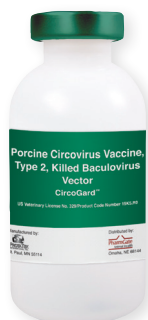

CircoGard™
circovirus

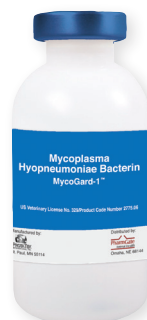

MycoGard-1™
Mycoplasma



MycoGard®
Mycoplasma

Water Medications



Pennchlor 64®
chlortetracycline



AIVLOSIN®
tylvalosin

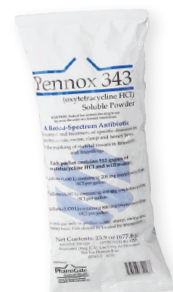

Pennox 343®
oxytetracycline

Medicated Feed Additives



AIVLOSIN® 17%
tylvalosin

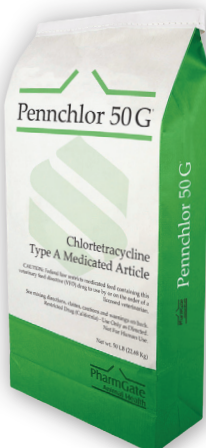

Pennchlor®
chlortetracycline



Neo-Oxy®
oxytetracycline
neomycin

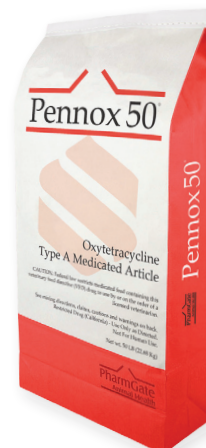

Pennox®
oxytetracycline

www.pharmgateAH.com

The power of blue

October usually brings the opportunity for me to attend the National FFA Convention, and 2017 afforded me that opportunity again. The FFA convention is a gathering of more than 65,000 attendees hailing from all 50 states and beyond. The great majority of the attendees are high school and college students, each of whom is dressed in the classic blue corduroy FFA jacket. It is literally a sea of blue anywhere you look.

For many years now, the AASV has had a booth in the expo area of the convention. The booth is staffed by me and AASV members who volunteer. We have a number of interactions with students, usually with an interest in either pigs or veterinary medicine, and sometimes both. We have various posters and educational resources for the students, but often they just stop in to visit with us. This year's volunteers at the booth were Drs Joel Sparks, Brad Schmitt, and Kevin Eggers. They did a great job of representing the association, the profession, and the pork industry! Ask them about all of the selfies taken with FFA members.

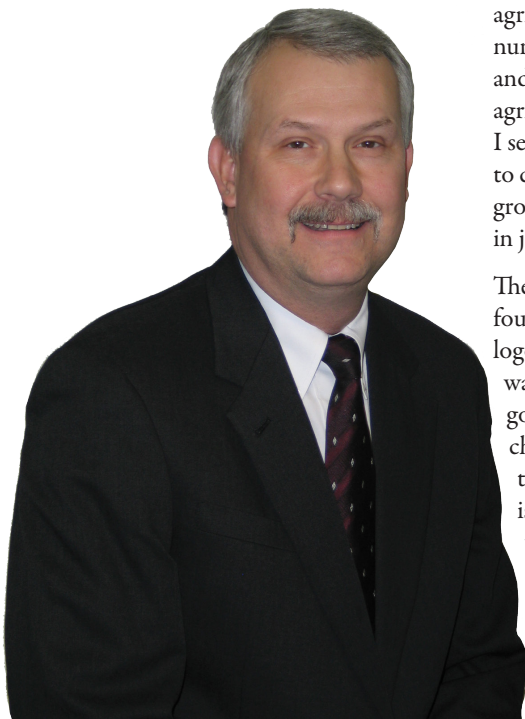

We also interact with a number of FFA advisors. Dr Sue Schulteis sends 400 advisor packets to be distributed. This enables advisors to pop in and grab a packet on the run if needed. The packets provide resources that can be used in the classroom and by individual students for projects. One advisor put it this way: "Our kids are bombarded by information from a number of sources, but your information is practical, straight forward, and fact-based." The advisors are very appreciative for these packets, but also for the fact that the AASV is there at the expo.

"We can't stubbornly rely only on what has worked in the past, nor can we abandon the success of the past in order to pursue an uncertain future. It is a balancing act that requires all members to carefully consider what the AASV can and should be doing for them."

Our booth was located near an area where there was music, line dancing, and karaoke. The talent and energy of many students was on full display. Also on display throughout the convention was an enthusiasm for agriculture and for leadership. The FFA nurtures both by allowing students to grow and find their way into fulfilling careers in agriculture. This is the "power of blue" that I see at the FFA convention. It is astonishing to consider the power and influence that this group will have on the future of agriculture in just a few short years.

The AASV has its own shade of blue. The founders of the AASP designed a stylized logo (that is still in use today) and they wanted to add color to the logo. Being the good stewards of AASP resources, they chose reflex blue as the color because it was the cheapest to use for the logo. This blue is still with us today at AASV. My staff will tell you that when I am asked about graphic art for an AASV publication, my reply is invariably "it looks good as long as it is blue!"

The AASV is similar to the FFA in that the "power of blue" for the AASV comes from our members. It was our members' enthusiasm for agriculture and leadership that formed the AASP in 1969. It is the same enthusiasm that has brought the AASV to where it is today. It is the same enthusiasm that will take us into the future. How the AASV nurtures and grows this enthusiasm is the responsibility of every member.

The AASV depends on the participation and input from its members. Sustaining and improving our existing programming must be complemented by meeting future challenges and seizing new opportunities. We can't stubbornly rely only on what has worked in the past, nor can we abandon the success of the past in order to pursue an uncertain future. It is a balancing act that requires all members to carefully consider what the AASV can and should be doing for them.

Over the years I have found the FFA convention to be a refreshing change of pace from my duties at AASV. Maybe it is just the energy and enthusiasm of the kids, but I believe that it is really the view of the future that refreshes me. One last note: one of my personal goals is to someday meet an AASV member who remembers visiting the AASV booth as an FFA member at the convention. To me that would be the embodiment of the "power of blue."

Tom Burkgren, DVM
Executive Director





NEW
250 mL vial

Fewer vials. Higher efficiency.

Save labor, time, and hassle with our new 250 mL vial.
The first and only injectable iron to be offered in this size.



NATURAL FORMULA

Uniferon[®] 200 is a strongly bound iron complex manufactured without the use of organic solvents or cyanide, avoiding trace residues of these components.



GLOBAL APPROVAL

Uniferon[®] 200 is the only injectable iron for baby pigs approved by the medical authorities in Europe, Asia and by the Food and Drug Administration (FDA) in the US.



HUMAN STANDARDS

Uniferon[®] 200 has a good safety profile and is manufactured to the same standards as those required for human medicine.



Uniferon[®]
The world's #1
injectable iron



Quality iron for your baby pigs

Uniferon[®] is a registered trademark of Pharmacosmos A/S

T: 908-769-7045

E: uniferon.us@pharmacosmos.com

us.uniferon.com



Looking back

How could 17 years have slipped by so quickly! In the summer of 2000, when the late Bob Morrison was president of AASP, I was living in the nurses' residence at the Toronto General Hospital where I was managing a gnotobiotic unit raising transgenic pigs for xenotransplantation. Just two of us ran the unit. The days were long and included several showers in and out. We were working extra hours every afternoon finalizing the gnotobiotic project. In my spare time I wrote or edited papers for Ontario Veterinary College scientists, but there was not much spare time available. During this busy time Cate Dewey asked if I would be interested in editing a swine veterinary journal. Knowing that my current job was ending, I took her offer, and the rest, as they say, is history. It was very hard to work the journal into my schedule until our pigs were gone, but in those early days, the journal was smaller and less formal. Gradually, the American Medical Association style was applied to the ancillary articles as well as the scientific papers.

Until it was abandoned around 2003, we had an ancillary called "What's Your



Interpretation" (WYI) that became a burden because we needed volunteers to submit suitable articles with a graph or table that could be presented for interpretation. Volunteers were not rushing in with submissions. By 2002, we were desperate for WYI submissions, and more or less press-ganged people into submitting suitable data, but I had begun to know who would be likely to have such data. When I happened to meet Steve Dritz at the 2002 annual meeting (actually I'd been stalking him), he said hello and I responded with "Let's cut to the chase, Steve. Will you give us a WYI for the May issue?" Steve laughed long and loud. But he gave us a submission.

"Looking back, becoming associate editor of the journal was one of the best decisions I have made in my life. But this journal and this association are not about looking back, they are always looking forward, changing as necessary to stay in the forefront of swine research."

I met with Tom Burkgren and Sue Schulteis at my first AASP meeting in Nashville and began to understand that these people were a community who knew and supported each other, celebrating and having great fun together at the annual gatherings. I have been to many veterinary meetings at home and abroad, but never another with the comradery found at AASV meetings. I had heard that there was a silent and a live auction and also that Tom Burkgren acted as auctioneer. To my surprise, with the first syllables out of his mouth, it was evident that Tom did not merely act as auctioneer, he really was an auctioneer! The folks at those auctions are incredibly generous with their bids and they have had some "big hairy audacious" goals. I saw funds raised for veterinary student scholarships intended to encourage the winners to consider a career in swine medicine. Remembering my own veterinary student years, it is easy to understand how encouraging

this would be. Under Tom's leadership and encouragement, new blood is always being brought into the AASV. In 2012, Terri O'Sullivan replaced Cate Dewey as Executive Editor, and now I am among the retirees. I will miss the rhythm of the work and the excitement of opening a new manuscript. A panoply of colorful and friendly people come to mind.

For example, Tim Blackwell, who borrowed a pail from the hotel cleaning crew to illustrate his Howard Dunne Memorial Lecture, at the end of it said "the Dunne is done," which may not have originated with Tim but it sounds like him. From year to year at the annual meetings, I found compatible people to hang out with – on that list were Sandy Amass (who taught us to juggle), Barb Straw (the horsey connection), and Cathy Rae (who shared sundaes with me at the veterinary student ice cream bar).

With just a single face-to-face meeting annually, I have bonded with Tina Smith, our talented graphics designer who also raises beef calves. Tina added pig photographs to the journal covers in 2004 and has continued to partner with John Waddell, whose aerial photos have brightened multiple covers. Karen Richardson has repeatedly saved my sanity by always knowing the status and location of all the submissions and being a great proof reader. Tom and Sue have always been there to handle problems. I will miss this group of friends forever.

Looking back, becoming associate editor of the journal was one of the best decisions I have made in my life. But this journal and this association are not about looking back, they are always looking forward, changing as necessary to stay in the forefront of swine research. I was drawn into this community of scientists more than 17 years ago and am the better for it. Thank you for making me one of the family – I have loved being a part of your lives.

Judi Bell, DVM, PhD
Associate Editor





Long-term impact of zinc supplementation in sows: Impact on claw quality

Miriam M. J. van Riet, MSc, PhD; Emilie-Julie Bos, MSc, PhD; Bart Ampe, MSc, DVM, PhD; Paul Bikker, MSc, PhD; Donna Vanhauteghem, DVM, PhD; Filip Van Bockstaele, MSc, PhD; Pieter Cornillie, DVM, PhD; Wim Van Den Broeck, DVM, PhD; Gijs Du Laing, MSc, PhD; Dominiek Maes, DVM, MS, MSc, PhD, Dipl ECPHM; Frank A. M. Tuytens, BSC-Hons, PhD; Geert P. J. Janssens, MSc, PhD; Sam Millet, DVM, PhD, Dipl ECPHM

Summary

Objectives: To evaluate the long-term impact of zinc (Zn) supplementation on claw lesions, claw conformation, and histological and mechanical claw characteristics of sows housed in groups on rubber top layer or concrete floors during gestation.

Materials and methods: Six groups of 21 ± 4 sows were allotted to group housing on different floor types for 80 days during gestation. Within each group, sows were randomly allocated to one of three diets supplementing a basal diet (46.6 and 128.9 mg Zn per kg during gestation and lactation, respectively) with 0, 50, or 100 mg Zn per kg. Claw lesion scoring, claw conformation, and horn growth and

wear measurements were performed at days 50 and 140 of every cycle. Histological and mechanical characteristics were evaluated on claw samples of 36 sows after slaughter.

Results: Dietary Zn supplementation affected heel horn erosion score ($P = .01$): sows supplemented with 100 mg Zn per kg diet had better scores. Distances between dermal papillae of the sagittal heel horn were larger ($P = .004$). Heel height was lower for sows supplemented with 0 and 100 mg Zn per kg than for 50 mg per kg ($P = .01$). Horn growth and wear were lower for sows housed on rubber at day 50 ($P < .001$, both variables), but not at day 140. Dermal papillae distance was shorter for sows on rubber ($P = .04$).

Implications: Unlike floor type and phase within the reproductive cycle, and under the conditions of this study, dietary zinc supplementation minimally influences claw quality.

Keywords: swine, claw conformation, claw lesion, dietary zinc concentration, rubber top layer

Received: December 23, 2016

Accepted: June 2, 2017

MMJVR, FAMT, SM: Animal Sciences Unit, Institute for Agricultural and Fisheries Research (ILVO), Melle, Belgium, and Department of Nutrition, Genetics and Ethology, Faculty of Veterinary Medicine, Ghent University, Merelbeke, Belgium.

EJB: Animal Sciences Unit, Institute for Agricultural and Fisheries Research (ILVO), Melle, Belgium, and Department of Obstetrics, Reproduction and Herd Health, Faculty of Veterinary Medicine, Ghent University, Merelbeke, Belgium.

BA: Animal Sciences Unit, Institute for Agricultural and Fisheries Research (ILVO), Melle, Belgium.

PB: Livestock Research, Wageningen University and Research Centre, Wageningen, the Netherlands.

DV, GPJJ: Department of Nutrition, Genetics and Ethology, Faculty of Veterinary Medicine, Ghent University, Merelbeke, Belgium.

FVB: Department of Applied Biosciences, Faculty of Bioscience Engineering, Ghent University, Ghent, Belgium.

PC, WVDB: Department of Morphology, Faculty of Veterinary Medicine, Ghent University, Ghent, Belgium.

GDL: Laboratory of Analytical Chemistry and Applied Ecochemistry, Faculty of Bioscience Engineering, Ghent University, Ghent, Belgium.

DM: Department of Obstetrics, Reproduction and Herd Health, Faculty of Veterinary Medicine, Ghent University, Merelbeke, Belgium.

Corresponding author: Prof Dr Sam Millet, Animal Sciences Unit, Institute for Agricultural and Fisheries Research (ILVO), Scheldeweg 68, 9090 Melle, Belgium; Tel: 003292722615; Fax: 003292722601; E-mail: sam.millet@ilvo.vlaanderen.be.

This article is available online at <http://www.aasv.org/shap.html>.

van Riet MMJ, Bos EJ, Ampe B, et al. Long-term impact of zinc supplementation in sows: Impact on claw quality. *J Swine Health Prod.* 2018;26(1):10–24.

Resumen - Impacto a largo plazo de suplementar zinc en hembras: Impacto sobre la calidad de la pezuña

Objetivos: Evaluar el impacto a largo plazo de suplementar zinc (Zn por sus siglas en inglés) sobre las lesiones, conformación, y características mecánicas e histológicas de la pezuña de hembras alojadas en grupos en pisos con una capa de hule o pisos de concreto durante la gestación.

Materiales y métodos: Se asignaron seis grupos de 21 ± 4 cerdas en alojamiento en grupo en diferentes tipos de piso por 80 días durante la gestación. Dentro de cada grupo, las hembras fueron asignadas aleatoriamente a una de tres dietas suplementando una dieta básica (46.6 y 128.9 mg de Zn por kg durante la gestación y lactancia, respectivamente) con 0, 50, ó 100 mg de Zn por kg. Se realizó un puntaje de lesión, conformación, crecimiento, y desgaste de la pezuña los días 50 y 140 de cada ciclo. Se evaluaron las características histológicas y mecánicas en muestras de pezuña de 36 hembras después del sacrificio.

Resultados: El suplemento con Zn en la dieta afectó el puntaje de erosión del talón de la pezuña ($P = .01$): las hembras suplementadas con 100 mg de Zn por kg de dieta tuvieron mejores puntajes. La distancia entre la papila dérmica de la pezuña del talón sagital fue

mayor ($P = .004$). La altura del talón fue más baja en las hembras suplementadas con 0 y 100 mg de Zn por kg que con 50 mg por kg ($P = .01$). El crecimiento y desgaste de la pezuña fueron menores en las hembras alojadas sobre hule en el día 50 ($P < .001$, para variables), pero no en el día 140. La distancia de la papilla dérmica fue más corta en las hembras sobre hule ($P = .04$).

Implicaciones: A diferencia del tipo de piso y de la fase dentro del ciclo reproductivo, y bajo las condiciones de este estudio, suplementar zinc en la dieta tiene una influencia mínima en la calidad de la pezuña.

Resumé - Impact à long terme d'un supplément de zinc chez les truies: Impact sur la qualité des onglons

Objectifs: Évaluer l'impact à long terme d'un supplément de zinc (Zn) sur les lésions aux onglons, la conformation des onglons,

et les caractéristiques histologiques et mécaniques des onglons de truies logées en groupe sur un plancher de ciment ou avec revêtement en caoutchouc durant la gestation.

Matériels et méthodes: Six groupes de 21 ± 4 truies furent assignés à un hébergement de groupe sur différents types de plancher pour 80 jours durant la gestation. À l'intérieur de chaque groupe, les truies ont été assignées à l'un des trois régimes alimentaires supplémentant une diète de base (46,6 et 128,9 mg Zn par kg durant la gestation et la lactation, respectivement) avec 0, 50, ou 100 mg de Zn par kg. Le pointage des lésions aux onglons, la conformation des onglons, et les mesures de la croissance et de l'usure de la corne ont été effectués aux jours 50 et 140 de chaque cycle. Les caractéristiques histologiques et mécaniques ont été évaluées sur des échantillons d'onglons de 36 truies suite à l'abattage.

Résultats: Le supplément alimentaire de Zn a affecté le pointage de l'érosion de la corne du talon ($P = 0,01$): les truies ayant reçu un supplément de 100 mg de Zn par kg avaient de meilleurs pointages. Les distances entre les papilles dermiques de la corne du talon sagittal étaient plus larges ($P = 0,004$). La hauteur du talon était plus basse pour les truies ayant reçu 0 et 100 mg de Zn que celles ayant reçu 50 mg par kg ($P = 0,01$). La croissance et l'usure de la corne étaient plus faibles pour les truies hébergées sur un tapis en caoutchouc au jour 50 ($P < 0,001$ pour les deux variables) mais pas au jour 140. La distance entre les papilles dermiques était plus courte pour les truies sur le caoutchouc ($P = 0,04$).

Implications: Contrairement au type de plancher et à la phase au cours du cycle de reproduction, et dans les conditions propres à la présente étude, un supplément alimentaire de zinc influence de façon minimale la qualité de l'onglon.

Claw quality is an important factor that influences the welfare and productivity of sows. Claw quality is evaluated by visual scoring for claw shape, shape dimensions, lesion scoring, and measurement of structural, physical, and biochemical properties of the claw horn.^{1,2} In sows, mainly claw lesion scores are evaluated to define claw quality, but other measurements, including claw conformation, horn growth and wear, and mechanical claw characteristics, are rarely evaluated. More recently, effect of diet on histological claw characteristics were assessed with or without partially substituting inorganic zinc (Zn), copper (Cu), and manganese (Mn) sources with their organic forms.^{3,4} Claw lesions are a common multifactorial disorder in sows, with malnutrition and floor type, among others, noted as predisposing factors.^{5,6} Claw lesions influence claw quality, but claw quality also influences the occurrence and severity of claw lesions. Furthermore, claw quality depends on the internal characteristics of the claw, including optimal horn production, which is influenced by a diffuse nutrient supply from the dermis to the avascular epidermis.^{2,7,8} An insufficient nutrient supply results in a disturbed diffusion of nutrients to the avascular epidermis. This negatively affects horn production, thereby increasing the susceptibility of the claw to damage from the environment.^{7,8} The structural,

regulatory, and catalytic functions of Zn are related to horn production.⁷ However, results from previous studies, mainly in cattle, are inconclusive: reports range from no effect or a reduction in claw lesion and lameness scores with varying dietary Zn concentrations.⁹⁻¹¹ In weaned pigs, claw quality was affected by dietary Zn level.¹² Studies in sows did not assess the impact of increased dietary Zn concentration, but showed similar claw lesion scores, neither deterioration nor better scores, or better scores with (partial) substitution of inorganic Zn, Cu, and Mn sources by organically bound Zn, Cu, and Mn,^{3,13-18} except in one study.¹⁹ Study duration may be important for detecting differences between treatment groups. A lack of effect of dietary Zn may have been related to an excessively short study duration: 12 months is the threshold reported in the literature.^{10,11,20} Claw quality may be affected internally by dietary Zn concentration, while floor type is an external factor in development of claw lesions.⁶ An increased occurrence of claw lesions is observed when sows are housed on fully or partly slatted concrete floors, whereas straw bedding seems to be positively associated with fewer and (or) less severe claw lesions.^{6,11,21} A rubber top layer on concrete floors appears to protect claws due to a cushioning effect.^{22,23} In a long-term study in sows, however, the risk of more severe claw lesions increased when sows were housed on a rubber floor.²⁴

Therefore, it was hypothesized that both dietary Zn concentration and floor type would influence claw quality in sows. The objective of this longitudinal study conducted over three reproductive cycles was to evaluate the effect of dietary Zn supplementation on claw quality characteristics in sows housed on two different floor types during gestation.

Materials and methods

All experimental procedures involving these animals were approved by the Institute for Agricultural and Fisheries Research (ILVO) Ethics Committee for animal experiments.

This longitudinal 2×3 factorial experiment was conducted according to the institutional and national guidelines for the care and use of animals.

Animals and management

Six groups of non-lame primiparous sows ($n = 131$ gilts, RA-SE Genetics, RA-SE Genetics NV, Ooigem, Belgium; <http://www.ra-se.com/nl/>) entered the study when their locomotion score was ≤ 60 mm on a 150-mm tagged visual analogue scale (tVAS) developed by Nalon et al.²⁵ These gilts were purchased per group (21 ± 4 sows per group) and quarantined for 4 to 6 weeks before their first insemination at days 233 ± 12 of age. The experimental period started 10 days before the first insemination (day 0) and the six successive production groups were monitored

during three reproductive cycles (3-week interval between groups). When a sow was removed before the end of the experiment ($n = 36$), a new gilt replaced her.

Body weight, backfat thickness, and body condition score (BCS) at the start of the study were 149 ± 21 kg, 16 ± 4 mm, and 3.0 ± 0.5 , respectively (mean \pm SD). Sows were vaccinated at day 55 of gestation against porcine reproductive and respiratory syndrome virus (Porcilis; MSD Animal Health, Boxmeer, The Netherlands), 7 and 4 weeks before parturition against neonatal diarrhea caused by *Escherichia coli* (Neocolipor; Merial, Lyon, France), and 1 week postpartum against parvovirus and erysipelas (Parvovirax; Merial). The sows were dewormed 17 days before parturition.

After weaning of the third reproductive cycle (end of the study), sows that had participated for at least 12 months in the experiment (ie, sows that had completed at least two reproductive cycles; $n = 95$) were transported to a commercial abattoir after the left and right front claw were marked with a color-coded tie wrap. After slaughter the following morning, both front claws were removed at the carpal joint and collected before the sows entered the scalding vat to preserve the metacarpal bones and claw structures. After the claw structures were collected for examination, the remaining parts of the front claws, including metacarpal bones, were frozen at -20°C .

Housing facilities

During the quarantine period (4 to 6 weeks), each purchased sow group (21 ± 4 sows per group) was housed as a static production group on concrete floors with straw bedding. The quarantine unit consisted of two pens with natural ventilation, no climate control, and artificial light.

Sows were housed in individual gestation crates during the insemination period (eg, shortly before the first insemination [day -10] to day 28 [insemination day 0] and from weaning [day -7] until 4 weeks after insemination [day 28] in their successive reproductive cycles). Housing and management conditions were similar for all sows. Housing was naturally ventilated, with artificial light and with temperature adjusted according to the outdoor temperature. In the first week after weaning, lights were on between 8:00 AM and

8:00 PM. Crates had partly slatted concrete floors (14.4%; 1.38 m^2 per sow).

During mid- to late gestation (day 28 to day 108), the sows were housed again in their static production groups. An electronic feeding system was used, with individual sow recognition through an electronic transponder in the sow's ear. Ventilation was maintained at $73 \text{ m}^3 \text{ d}^{-1} \cdot \text{sow}^{-1}$ and indoor temperature was set at 20°C . Light was artificial, and in each pen, one light source was illuminated during the night so that sows could easily access the feeding system. The group-housing facility consisted of four pens ($4.45 \text{ m} \times 18.75 \text{ m}$; 40.4% slatted floor). Two of the four pens, oriented diagonally to each other, had a similar floor type: either concrete slats and solid concrete lying areas or concrete slats covered with rubber (EasyFix; Rubber Products Ltd, Galway, Ireland) and rubber lying mats (Gummiwerk Kraiburg Elastik GmbH & Co Kg, Tittmoning, Germany) on 50% of the solid concrete floor area ("concrete" or "rubber" floor type, respectively).²⁶ At the start of the study, production groups were alternately assigned to the concrete or rubber floor type during group housing and returned to the same floor type for the duration of the experiment. Per pen, two rubber balls and a static and dynamic rotating grooming brush were provided as environmental enrichment.

From 1 week before the expected parturition date until weaning (day 108 to day 143), sows were housed individually in units with 10 farrowing crates. Housing and management conditions were similar for all sows. Ventilation for the farrowing units was adapted to the temperature. The indoor temperature was set to 23°C and light was artificial. The crates within the pen had a steel slatted floor (crate size 1.33 m^2), which had a nonslip section, and the pen had a PVC-slatted floor (pen size 3.60 m^2). Floor heating ($0.60 \text{ m} \times 0.45 \text{ m}$) and heat lamps were provided in the pen for the piglets at the beginning of lactation.

Dietary treatment

All primiparous sows (gilts) in quarantine (4 to 6 weeks) were fed a pre-experimental gestation diet formulated according to NRC recommendations²⁷ and commercial standards for gestating sows. The pre-experimental diet was fed ad libitum and contained 895 g per kg dry matter (DM), 127.3 g per kg crude protein, 301.5 g per kg

neutral detergent fiber (NDF), 155.4 g per kg acid detergent fiber (ADF), 23.5 g per kg acid detergent lignin (ADL), 27.9 g per kg crude fat, 70.2 g per kg crude ash, 128.6 g per kg starch, 66 g per kg sugar, 121 mg per kg total Zn (ie, ± 21 mg Zn per kg originating from ingredients and 100 mg per kg added Zn as ZnO via premix), and 4.7 g apparent ileal digestible lysine per kg diet.

Throughout the experimental period, sows were fed a gestation and lactation diet formulated according to NRC recommendations²⁷ and commercial standards (tables 1 and 2), except for Zn. Phytase was added via the premix to simulate practical conditions. The gestation diet was provided 7 days before the first insemination, or after weaning of the preceding reproductive cycle (day -7) until 1 week before parturition (day 108). The sows were fed twice daily from day -7 to the end of the first 4 weeks of gestation (day 28), in total 2.3 kg per day, whereas during mid-gestation and up until the end of gestation (day 28 to day 108), sows were fed 2.6 kg per day. The lactation diet was provided from 1 week before parturition until weaning (day 108 to day 143). The sows were fed twice daily and received 3 kg feed provided in two equal portions during the week before parturition (day 108 to day 115). After parturition, 0.25 kg of feed per suckling piglet was gradually supplemented in addition to 3 kg feed, also provided in two equal portions daily.

Throughout the experiment, all sows had ad libitum access to drinking water, except in the first 4 weeks of gestation, when water was automatically provided through nipple drinkers for 15 minutes every hour and for 45 minutes while feeding to reduce water spillage.

Within each static production group, equal numbers of sows were randomly allocated to one of three dietary treatment groups, depending on the number of sows. The dietary treatments differed in Zn concentration: Zn not supplemented, originating from ingredients only; 50 mg Zn per kg supplemented; and 100 mg Zn per kg supplemented. Thus, total dietary Zn concentration was expected to remain below the European Union (EU) upper limit of 150 mg per kg (EU regulation 2016/1095). The Zn supplement comprised 50% inorganic Zn as ZnO (75% Zn) (33.3 or 66.6 g ZnO per 1000 kg feed, INVE Belgium

Table 1: Ingredient composition of the gestation and lactation diet fed to sows (n = 131 at start of study) through three reproductive cycles to assess the effect of dietary Zn supplementation on claw quality measurements when sows were housed on different floor types during group housing

Ingredients (g/kg as fed)	Gestation	Lactation
Wheat	180	213
Barley	180	100
Maize	152	250
Wheat middling	150	23
Beet pulp	120	43
Soybean meal	89	166
Soybeans heated	NA	12
Soybean oil	21	NA
Alfalfa meal	47	94
Beet molasses	30	30
Premix 3%*	30	NA
Premix 2.75%†	NA	27.5
Lard	NA	30
Limestone	NA	9.4
L-Valine	NA	0.9
L-Threonine	0.8	0.7
DL-Methionine	0.7	0.3
L-Lysine HCL	0.1	0.5
L-Tryptophan	NA	0.1
Salt	0.05	NA

* Premix 3% analysis found in Supplementary materials.

† Premix 2.75% analysis found in Supplementary materials.

NA = not applicable (ingredients not added to the gestation or lactation diet).

NV, Baasrode, Belgium), and 50% organic Zn as Availa Zn containing 10% Zn in an amino-acid complex: single amino acids from hydrolysed soy proteins (molar ratio 1:1, 250 or 500 g Availa Zn per 1000 kg feed, Zinpro Corporation, Eden Prairie, Minnesota).

Claw quality measurements

On all sows, claw lesion scores, claw conformation, and horn growth and wear were determined. For some claw quality measurements (horn wall Zn concentration and histological and mechanical claw characteristics), 36 sows (12 from each dietary treatment group and at least one from each static production group) were selected. These sows were selected according to three criteria: three reproductive cycles completed; remained in their group of origin, ie, the group the sow was allocated

to at the start of the experiment (repeat breeders that were transferred to another group allocated to the same treatment group and floor type did not meet this criterion); and housed in their group during the entire gestation period (eg, not separated from the group during the group housing period).

Claw lesion scoring, measurements of claw conformation and horn growth and wear were performed at the start of the experiment (day -10, baseline) and then on day 50 and day 140 of every cycle. For these measurements, sows were placed in a sow chute (FeetFirst sow chute; Zinpro Corporation, Eden Prairie, Minnesota), and lifted off the ground for maximum 15 to 20 minutes. At day 140, the supporting beam of the sow chute was disinfected between lactating sows to prevent pathogen transmission. After cleaning (water, brush

and [or] hoof knife) and drying the claws with paper towels, lateral and medial claw digits of front and hind claws were scored for eight types of claw lesions using a tagged visual analogue scale (tVAS) of 160 mm (Figure 1). This scoring system was based on the “Zeugenklauwen check” (Wageningen University) and the method of FeetFirst by Zinpro Corporation.²⁸ All claw digits were scored for seven claw conformation measurements¹² using a digital calliper (Mitutoyo Belgium NV, Kruibeke, Belgium) following a methodology adapted from Calabotta et al²⁹ and Vermunt and Greenough.² These dimensions were subsequently used to calculate the distal toe angle, sole area, claw volume, claw horn size, and toe:heel ratio as described in van Riet et al.¹² For horn growth and wear, a superficial reference point was incised into the dorsal horn wall of both claw digits of the left front and right hind claw by carving a small indentation with a hoof knife 0.5 cm below the periople and colored with Indian ink.¹² At the subsequent evaluation (day 50 or day 140), the displacement above and below this reference point was measured using a digital calliper to determine horn growth, wear, and net horn growth.¹² A new superficial reference point was incised into the dorsal horn wall and colored with Indian ink. For each above-mentioned claw quality variable, a mean score per sow per parameter per scoring day (day 50 or day 140) was calculated and used for further analysis.

Histological and mechanical horn characteristics were determined after slaughter. For histological examination, a claw horn wall (abaxial) sample, including the periople, and heel horn sample closest to the heel horn-sole junction (containing both the epidermal and dermal layer) of each claw digit of the front claws was collected using a scalpel. The left lateral and right medial claw digit samples were fixed in a 3.5% buffered formaldehyde solution. Subsequent preparation steps are described in van Riet et al.¹² After H&E staining, standardized photographs (n = 5 positions per section; 10× magnification) of the sagittal heel horn sections (perpendicular to the bearing surface) and transverse horn wall and heel horn sections (parallel to the bearing surface) were examined. Each photograph of the transverse horn wall and sagittal heel horn sections was alternately assessed once by one of two observers. All transverse heel horn sections were assessed once by one

Table 2: Analyzed and calculated* nutrient composition of the gestation and lactation diet†

Chemical analysis (g/kg)	Gestation			Lactation		
	0	50	100	0	50	100
DM	877.4	876.9	877.1	880.0	878.3	879.6
Crude ash	56.9	56.9	56.7	62.8	63.0	63.0
Crude protein	136.7	136.9	136.8	160.8	161.0	160.7
Crude fat	41.2	41.7	41.6	51.6	52.0	51.3
Crude fibre	64.5	65.0	66.3	58.1	61.1	58.7
Starch	277	270	268	313	304	314
Sugar	55.8	56.2	55.2	55.4	55.2	53.6
Acid detergent fiber	72.0	72.4	68.5	54.8	54.1	60.3
Neutral detergent fiber	167	162	159	121	118	116
Acid detergent lignin	9.9	10.6	11.5	6.8	6.3	7.0
Ca	8.1	8.6	9.1	12.3	12.1	10.8
P	4.4	4.3	4.3	5.0	4.9	5.0
Cu (mg/kg)‡	18.6 (15-25)	14.1 (13-15)	13.8 (13-15)	20.9 (19-22)	20.8 (19-22)	19.9 (19-22)
Zn (mg/kg)‡	46.6 (45-49)	81.9 (77-91)	124.4 (119-132)	128.9 (116-137)	184.3 (167-209)	229.0 (206-256)
ID Lysine	6.0			7.9		
ID Methionine	2.3			2.9		
ID Methionine + Cysteine	4.0			4.2		
ID Threonine	4.3			5.5		
ID Tryptophan	1.2			1.6		
ID Arginine	6.6			8.3		
ID Leucine	7.6			10.1		
ID Isoleucine	3.8			5.1		
ID Histidine	2.7			3.3		
ID Valine	4.5			6.6		
ID Phenylalanine	4.7			6.2		
NEv (MJ/kg)	9.0			9.4		

* Chemical analyses of ileal digestible (ID) amino acids and net energy (NEv) for pigs are calculated according to the feed tables of the Centraal Veevoederbureau (CVB, the Netherlands), 2007. Net energy for pigs is expressed as Megajoules per kg.

† Dietary treatment is presented as 0, 50, or 100 mg Zn/kg, supplementing a basal diet that contained 46.6 mg Zn/kg and 128.9 mg Zn/kg during gestation and lactation, respectively.

‡ Zn and Cu concentration are the average values of multiple feed sample analyses. Ranges for both minerals' concentrations in the gestation and lactation diet over time are presented in parentheses. The analyzed Zn concentration of the premix in the gestation diet was 260 mg/kg, which represented 7.8 mg Zn/kg in the final diet for the 3% premix. The analyzed Zn concentration of the premix in the lactation diet was 4366 mg/kg, which represented 120 mg Zn/kg in the final diet for the 2.75% premix.

observer. To calculate the histological claw characteristics, 93.4% of the transverse horn wall sections, 98.7% of the transverse heel horn sections, and 71.1% of the sagittal heel horn sections were included. These characteristics included the number of dermal papillae for the sagittal heel horn or dermal lamellae for the transverse horn

wall sections per 1000 μm , width, distance, and length of longest dermal papillae or lamellae, and horn tubules density.¹² The remaining sections were excluded because of broken samples and absence of the dermis layer. To assess differences between the two observers, histological measurements of 14 sagittal heel horn sections were conducted

by both observers, using an average of five photographs per section. A paired *t* test and Pearson correlation were used to analyze the differences and correlations between observers.

For mechanical horn examination, an abaxial horn wall sample of the lateral and medial digits of the right front claw (mean

Figure 1: Tagged visual analogue scale (tVAS) for claw lesion scoring in sows, created on the basis of scoring guides of Wageningen University and FeetFirst (Zinpro Corp, Eden Prairie, Minnesota). To score the claw area for claw lesions, a vertical bar was drawn on the line and the distance from 0 mm determined. The average distance of lateral and medial digits from front and hind claws per claw lesion type was used for further analyses. For skin lesion scoring, only skin lesions around the claw and dewclaw were included. Hemorrhages were included in scoring the horn wall for horizontal cracks. If hemorrhages are present, but no cracks, the score is 40 mm. The length of the dewclaw was determined by pushing the dewclaw against the claw to determine whether the dewclaw exceeds heel height.

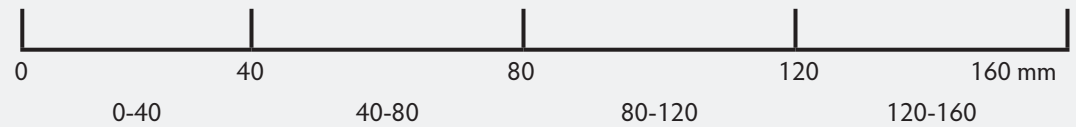

Heel horn	Healthy	Slight overgrowth and/or erosion	Moderate overgrowth and/or erosion with moderate cracks	Severe overgrowth and/or erosion with cracks
Heel/sole junction	Healthy	Slight detachment of the heel-sole junction	Extensive detachment of the heel-sole junction	Long, deep detachment of heel-sole junction
White line	Healthy	Shallow and/or short detachment along white line	Clear and/or long detachment along white line	Long, deep detachment along white line
Skin lesions	None	Mild injury	Moderate/substantial injury	Severe, inflammation, infection of periople
Horizontal horn wall cracks	None	Hemorrhage and short shallow horizontal crack	Long shallow horizontal crack	Multiple and/or deep horizontal crack(s)
Vertical horn wall cracks	None	Short shallow vertical crack	Long shallow vertical crack	Multiple and/or deep vertical crack(s)
Claw length	Normal, ± 50 mm	One or both toes slightly longer	One or both toes significantly longer	Long toes that complicate locomotion
Dewclaw length	Normal, ± 20 mm	Dewclaw slightly longer	Dewclaw touches floor when standing	Dewclaw is cracked or (partially) missing

length, width, thickness: $27 \times 17 \times 4.5$ mm) was sawn using an oscillating saw, after which the underlying tissues were removed with a scalpel. The angle adjacent to the dorsal border and periople was marked. The horn wall samples were weighed and individually stored in a vacuum (to prevent fluctuations in moisture content) at -20°C until analysis. Horn wall samples of the left front claw could not be used to test the mechanical horn characteristics because of the incised superficial reference point for horn growth and wear measurements. The lateral or medial abaxial horn wall samples ($n = 36$ sows, 1.7 ± 0.4 g) were defrosted during 24 hours at 4°C and weighed (1.8 ± 0.4 g). The horn wall samples were cut into the required dimensions: two subsamples of 20 mm length and 6 mm width with a variable thickness using a mitre cutter with

lever transmission (LOWE 3140/HÜ, Original LOWE, Gebr. Schröder GmbH, Kiel, Germany) and were weighed. On the first day, the two subsamples of the lateral or medial sample were tested. The subsample with the marked angle adjacent to the dorsal border and periople was tested first, followed by the subsample without marking. The two subsamples of the other lateral or medial sample from the same sow were tested the next day in the opposite order to that used the first day. The horn wall samples were tested with a three-point bending test (Texture Analyzer; Stable Micro Systems Ltd, Surrey, United Kingdom) according to the methodology described by Franck et al.³⁰ The test characteristics (stress area and strain height) were adjusted for each sample because the sample thickness and weights differed. The span between the two

supports was set to 15 mm and the sample was compressed over a distance of 5.5 mm (eg, maximal deformation) using a force transducer (load cell, 30 kg) exerted in the middle of the span distance of 15 mm. Each sample was tested with a loading velocity of 1 mm per minute and 15 mm per minute to determine visco-elastic properties of the claw horn. The time between the velocities ranged between 1 and 1.5 hours. A force-deformation curve was generated and converted (Exponent Software; Stable Micro Systems Ltd) to a stress-strain diagram. Then Young's modulus, yield stress, and maximal stress were determined.³⁰ Young's modulus is a measure of the rigidity and stiffness of the horn and is represented as the slope of the linear phase of the initial line. Yield stress is the point on the stress-strain diagram in which the material starts to lose its

mechanical function and material properties begin to change at further loading. Yield stress is represented as the point of the line where the line becomes nonlinear, using a parallel straight line with the same slope as the initial line (strain equal to 1%), where the intersect with the stress-strain diagram is defined as the yield stress.³⁰ Maximal stress is represented as the maximal load a sample can withstand.³⁰ The abaxial horn wall samples were stored in a vacuum at -20°C post testing until further analysis. Abaxial horn wall samples were dried at 103°C to a constant weight and analyzed for Zn content.

Chemical analysis

Feed samples of the gestation and lactation diets were collected from each batch and ground to pass through a 1-mm sieve for Near Infrared Spectroscopy evaluation, then pooled per dietary treatment group every 3 months for proximate analysis according to international standard methods accredited by ISO 17025.³¹ Dry matter, crude ash, crude protein, crude fat, calcium, and phosphorus content were determined according to 71/393/EEC, ISO 5984, ISO 5983-2, ISO 6492, ISO 6490/1, and ISO 6491, respectively. The American Oil Chemists' Society (AOCS) approved procedure Ba 6a-05 was used to determine crude fiber content, and the procedures described in Van Soest et al³² were used to determine ADF, NDF, and ADL.

The homogenized feed sample was further ground to pass through a 0.5-mm sieve, and three of five samples per dietary treatment were subjected to Zn and Cu analysis. Copper was analyzed to assess possible antagonistic effects of Zn on Cu metabolism. Feed samples (1 g) were ashed and digested with HNO₃ on a hot plate (150°C) for at least 30 minutes, then transferred to a 50-mL flask. The Zn and Cu concentrations were determined by inductively coupled plasma optical emission spectrometry (ICP-OES, Vista MPX; Varian Inc, Palo Alto, California).

The Zn concentration in abaxial horn wall samples (± 0.8 g) was determined by ICP-OES, Vista MPX after the samples were diluted in 10 mL 6N HNO₃ for 12 hours, heated on a hot plate at 150°C for approximately 2 hours, and transferred to a 50-mL flask.

Statistical analysis

Linear mixed models were used for the outcome variables (Y) mean claw-lesion scores, claw conformation, horn growth, horn wear, and net horn growth. Dietary Zn supplementation (X_{Zn}), floor type (X_{FT}), phase within the reproductive cycle (X_{phase}), parity (X_{par}), digit (X_{dig} , lateral or medial), claw (X_{claw} , front or hind), the two-way interactions between dietary Zn supplementation or floor type and phase within the reproductive cycle and interaction between dietary Zn supplementation and floor type were included as fixed effects. Reproductive cycle (B_{cycle}), sow (B_{sow}) and group (B_{group}) were included in the models as random effects to correct for the repeated measurements.

An example of a model is given in the following equation:

$$Y = \beta_0 + \beta_1 X_{Zn} + \beta_2 X_{FT} + \beta_3 X_{phase} + \beta_4 X_{par} + \beta_5 X_{dig} + \beta_6 X_{claw} + \beta_7 X_{Zn} X_{phase} + \beta_8 X_{FT} X_{phase} + \beta_9 X_{Zn} X_{FT} + B_{cycle} + B_{sow} + B_{group}$$

Similar linear mixed models were used to analyze the histological and mechanical claw characteristic data. Fixed and random effects included in the models differed according to the sampled structures (eg, only right front claw was used for mechanical claw characteristic versus all claws included for claw-lesion scoring) and time of sampling (eg, claw structures collected after slaughter versus multiple observations throughout the reproductive cycle). For the histological claw-characteristic data, dietary Zn supplementation, floor type, leg (left or right front), digit, and interaction between dietary Zn supplementation and floor type were included as fixed effects. Sow and group were included in the model as random effects. For the mechanical claw-characteristic data, dietary Zn supplementation, floor type, digit, and interaction between dietary Zn supplementation and floor type were included in the linear mixed model as fixed effects, and sow and group as random effects per test velocity. Differences between test velocities and between two samples of the same digit of the same sow were analyzed using a paired sample *t* test.

Non-significant interactions were excluded from all final models and *P* values of the main effects are presented. In case of a significant interaction, partitioned post-hoc *P* values are presented. Partitioned post-hoc tests are tests of the simple effects of one variable for each level of the other variable. In the case of

non-significant interactions, an all pairwise comparisons post-hoc test was performed. The *P* values of all post-hoc tests were corrected for multiple comparisons using the Tukey-Kramer method.

The analyzed data were considered to be sufficiently normally distributed, on the basis of the graphical evaluation (histogram and QQ-plot) of the residuals. All analyses were performed using SAS 9.4 (SAS Institute Inc, Cary, North Carolina).

Results

The interaction between dietary Zn supplementation and floor type was not significant for any of the outcome variables (*P* > .05). Effects of parity, claw (front and hind), and claw digits (lateral and medial) on claw quality measurements are presented in the supplementary data and supported by Suppl tables 1 and 2.

Throughout three reproductive cycles, 36 sows (27.5% of 131 gilts that entered the study), of which 9, 16, and 11 sows from the 0-, 50-, and 100-mg supplemented Zn per kg treatment group, respectively, were removed from the experiment, and 21 of them were replaced by non-lame primiparous sows. Sows were removed for several reasons: spontaneous death (*n* = 10), euthanasia (rectal or uterine prolapse, severe locomotion disorders; *n* = 7), or reproductive failure after multiple attempts (*n* = 19). In total, 70 sows remained in their group of origin, whereas 26 sows (repeat breeders) were transferred to another group allocated to the same dietary treatment and floor type. In total, 92 of 95 sows were slaughtered. Two sows died after their third parturition and front claws from one sow were collected post mortem after euthanasia at the ILVO experimental farm directly after the other sows of the group were loaded for transport.

Claw lesion scores

Dietary Zn supplementation influenced the mean heel horn erosion score (*P* = .01), showing a 3.48-mm higher (worse) mean heel horn erosion score for the non-supplemented sows compared to the 100-mg Zn per kg supplemented sows (Table 3). Other types of claw lesions did not differ between dietary treatment groups (*P* > .05). Floor type did influence some claw lesion scores.²⁶ Mean claw lesion scores were lower at day 50 than at day 140 of the reproductive cycle, except for horizontal wall cracks (Table 3).²⁶

Claw conformation

Claw dimension measurements. An interaction was found between dietary Zn supplementation and phase within the reproductive cycle for the mean sole (base) length ($P = .03$), showing shorter sole lengths for the non-supplemented sows than for the 50-mg Zn per kg supplemented sows at day 140 (Table 3). Mean heel height was influenced by dietary Zn supplementation ($P = .01$), with lower heel heights for the non-supplemented and 100-mg Zn per kg supplemented sows compared with the 50-mg Zn per kg supplemented sows (Table 3).

Independent of dietary Zn supplementation, the mean toe height and mean claw length of sows were lower and shorter, respectively, for the rubber floor than for the concrete floor ($P = .001$ and $P = .04$, respectively) at day 50 (Table 4). Mean heel height tended to be lower for sows housed on the concrete floors at day 50 ($P = .06$) and was lower for sows housed on the rubber floors ($P = .04$) at day 140. The interaction between floor type and phase within the reproductive cycle was not significant for claw width. Mean claw width did not differ between floor types.

Mean length of the dorsal border, diagonal claw length, toe height, heel height, and claw length were all shorter at day 50 than at day 140; claw width was the only exception (Table 3).

Claw morphology calculations. The mean claw volume was less ($P = .03$) for non-supplemented sows and tended to be less ($P = .06$) for the 100-mg Zn supplemented sows than for 50-mg Zn per kg supplemented sows. The mean toe:heel ratio was influenced by dietary Zn supplementation ($P = .02$), with a higher ratio for the non-supplemented sows compared with the ratio of the 50-mg Zn per kg supplemented sows. Distal toe angle, sole area, and claw horn size did not differ (Table 3).

The mean distal toe angle, sole area, and toe:heel ratio were lower for sows housed on rubber floors than for sows housed on the concrete floors at day 50 (Table 4). Mean claw volume was lower for the rubber floor type compared with the concrete floor type at day 140 ($P = .01$). The mean claw horn size did not differ (Table 4).

Mean distal toe angle and toe: heel ratio were lower, while mean sole area, claw volume, and claw horn size were higher at day 140 than at day 50 of the reproductive cycle (Table 3).

Horn growth and wear. Horn growth and wear did not differ between dietary treatment groups (Table 3). At day 50, horn growth and wear were lower for sows housed on rubber floors than on concrete floors. At day 140, horn growth and wear did not differ between floor types (Table 4). Net horn growth (horn growth minus wear) did not differ between dietary treatment groups nor between floor types at day 50 and day 140 (tables 3 and 4).

Net horn growth differed between day 50 (-4.2 mm, horn wear dominated) and day 140 (+4.4 mm, horn growth dominated) ($P < .001$).

Histological claw characteristics. Length of the longest dermal papillae ($P = .83$) and width of papillae ($P = .13$) did not differ between observers. Differences between observers were found for sample length ($P = .03$; confidence interval [CI] 3.3-57.8 μm , mean difference 30.5 μm), number of dermal papillae ($P = .003$; CI -0.9 to -0.2, mean difference 0.6), number of dermal papillae per 1000 μm ($P = .003$, CI -1.0 to -0.2, mean difference -0.6), and distance between papillae ($P = .02$, CI 9.1-100.3 μm , mean difference 54.7 μm). Correlation coefficients of inter-observer reliability were 0.95 for sample length, 0.79 for dermal number, 0.96 for longest length, 0.43 for distance between papillae, and 0.94 for papillae width. On the basis of the high inter-observer reliability (except distance between papillae) and the numerically irrelevant (but significant) differences, observer was not included in the final statistical models.

The number of dermal lamellae per 1000 μm , distance between lamellae, width of the lamellae, or length of the longest lamellae of the transverse horn wall did not differ between dietary treatment groups nor between floor types (Table 5).

The distance between the dermal papillae of the sagittal heel horn tended to be shorter for the non-supplemented sows ($P = .08$) and was shorter for the 50-mg Zn per kg supplemented sows ($P = .003$) compared with the 100-mg Zn per kg supplemented sows (Table 5). The number of dermal papillae per 1000 μm , width of the papillae, or length of the longest papillae of the sagittal heel horn did not differ ($P > .05$) between dietary treatment groups.

Independent of dietary Zn supplementation, the length of the longest papillae of the

sagittal heel horn tended to be shorter and the distance between dermal papillae was shorter for sows housed on rubber floors than sows housed on concrete floors (Table 5). The number of dermal papillae per 1000 μm or width of the papillae did not differ between floor types (Table 5).

The density of the heel horn tubules of the transverse heel horn, expressed as the number of horn tubules within a defined surface area of 1 mm^2 , did not differ between dietary treatment groups nor between floor types (Table 5).

Mechanical horn characteristics. Horn wall Zn concentration did not differ between dietary treatment groups (Zn concentration in DM was 128, 122, 120 mg Zn per kg for non-supplemented, 50-mg per kg- and 100-mg per kg supplemented sows, respectively; $P = .39$) nor between floor type treatments (Zn concentration in DM was 123 and 124 mg Zn per kg for concrete and rubber floor types, respectively; $P = .86$).

Thickness of the abaxial horn wall sample did not differ with dietary Zn supplementation ($P = .94$) nor with floor type ($P = .77$). None of the mechanical abaxial horn wall characteristics were significantly affected by dietary Zn supplementation or floor type (Table 6). Young's modulus differed between 1 mm per minute and 15 mm per minute test loading velocities ($P = .01$); tended to differ for maximal stress ($P = .07$); and did not differ for yield stress ($P = .22$), showing visco-elastic properties of the horn wall. Differences between the two horn wall samples per claw digit per sow for both test velocities were found for Young's modulus, yield stress, and maximal stress ($P < .001$).

Discussion

The welfare and productivity of sows can be affected by poor claw quality. In the present study, multiple claw characteristics were determined to evaluate claw quality in response to dietary Zn supplementation. Minor effects on claw quality measurements were found irrespective of floor type. Possible factors that overruled the potential influence of Zn in the present study are the overall good claw lesions score – with a mean lesion score close to the upper threshold of 40 mm for healthy claws – and the unexpectedly high background Zn supply via pre-mix in the

Table 3: Effect of dietary Zn supplementation on mean claw lesion scores, claw conformation (claw dimensions and calculation) and horn growth and wear* at day 50 and day 140 from sows housed on different floor types during group housing and followed through three reproductive cycles (n = 131 at start of study)

Dietary treatment‡	Reproductive cycle						P†	
	Day 50			Day 140			Zn	Cycle
	0	50	100	0	50	100		
Claw lesion type (mm)								
Heel horn erosion	48.2 [46.6, 49.8]	47.3 [45.6, 49.1]	44.3 [42.8, 45.8]	60.1 [58.7, 61.5]	58.1 [56.8, 59.5]	57.2 [55.7, 58.6]	.01	< .001
Heel/sole junction separation	41.8 [40.4, 43.1]	39.4 [38.0, 40.8]	40.0 [38.6, 41.3]	53.5 [52.1, 54.9]	52.1 [50.7, 53.4]	50.6 [49.2, 52.1]	.14	< .001
White line separation	48.5 [47.1, 50.0]	45.5 [43.9, 47.0]	45.7 [44.2, 47.1]	55.2 [53.5, 56.8]	53.8 [52.1, 55.6]	53.3 [51.6, 55.0]	.13	< .001
Skin lesions	18.9 [17.8, 20.1]	22.9 [21.5, 24.3]	22.2 [21.0, 23.5]	26.3 [25.0, 27.6]	26.5 [25.2, 27.8]	26.6 [25.3, 27.9]	.11	< .001
Horizontal wall cracks	41.9 [40.5, 43.4]	42.1 [40.6, 43.7]	42.1 [40.6, 43.6]	42.4 [41.0, 43.8]	44.1 [42.6, 45.6]	43.2 [41.7, 44.6]	.61	.26
Vertical wall cracks	26.2 [24.6, 27.9]	28.2 [26.6, 29.8]	28.4 [26.8, 29.9]	29.9 [28.5, 31.4]	32.2 [30.6, 33.9]	29.9 [28.3, 31.4]	.36	.002
Overgrown claw	30.9 [29.8, 32.1]	28.3 [27.1, 29.5]	29.1 [28.0, 30.2]	38.8 [37.7, 39.9]	38.7 [37.5, 39.8]	37.9 [36.7, 39.0]	.66	< .001
Overgrown dewclaw	34.5 [33.1, 36.0]	34.1 [32.5, 35.8]	35.6 [34.1, 37.2]	41.0 [39.5, 42.5]	40.9 [39.2, 42.5]	41.0 [39.5, 42.5]	.88	< .001
Claw dimensions (mm)								
Sole (base) length	24.8 [24.6, 25.1]	24.9 [24.6, 25.2]	24.4 [24.1, 24.6]	26.3 [26.0, 26.6]	27.2 [26.8, 27.5]	26.8 [26.5, 27.1]	¶	¶
Claw width	27.5 [27.2, 27.7]	27.9 [27.6, 28.1]	27.3 [27.1, 27.6]	27.2 [26.9, 27.4]	27.6 [27.3, 27.8]	27.5 [27.2, 27.7]	.67	.18
Length dorsal border	43.1 [42.8, 43.4]	42.5 [42.2, 42.7]	42.7 [42.4, 43.0]	48.3 [48.0, 48.6]	48.1 [47.8, 48.5]	48.2 [47.9, 48.6]	.90	< .001
Diagonal claw length	55.0 [54.6, 55.4]	54.9 [54.5, 55.3]	55.2 [54.8, 55.5]	59.5 [59.1, 59.9]	59.4 [59.0, 59.8]	59.3 [58.9, 59.7]	.56	< .001
Toe height	35.4 [35.1, 35.7]	35.3 [35.1, 35.6]	35.1 [34.8, 35.4]	36.2 [35.9, 36.6]	35.9 [35.5, 36.3]	36.3 [36.0, 36.6]	.71	.001
Heel height	8.0 [7.6, 8.3]	8.2 [7.8, 8.5]	8.3 [8.0, 8.7]	11.2 [10.9, 11.6]	12.2 [11.8, 12.5]	11.1 [10.7, 11.4]	.01	< .001
Claw length	50.2 [49.8, 50.6]	50.1 [49.7, 50.4]	50.1 [49.7, 50.5]	52.0 [51.6, 52.4]	51.5 [51.1, 51.9]	52.2 [51.7, 52.6]	.91	< .001
Claw calculations								
Distal toe angle (°)	56.7 [56.0, 57.4]	57.3 [56.6, 58.0]	56.5 [55.8, 57.2]	49.7 [49.0, 50.4]	49.3 [48.5, 50.0]	50.2 [49.5, 50.8]	.88	< .001
Sole area (mm ²)	1384 [1365, 1403]	1400 [1380, 1419]	1373 [1355, 1391]	1418 [1399, 1437]	1424 [1403, 1445]	1441 [1421, 1461]	.97	< .001
Claw volume (mm ³)	11091 [10585, 11598]	11532 [11013, 12052]	11540 [11025, 12056]	15961 [15385, 16538]	17248 [16639, 17858]	15823 [15233, 16413]	.03	< .001
Claw horn size (mm ²)	1520 [1499, 1540]	1537 [1516, 1558]	1515 [1495, 1534]	1624 [1603, 1645]	1641 [1619, 1663]	1638 [1617, 1660]	.64	< .001
Toe: heel ratio	3.9 [3.6, 4.3]	3.8 [3.7, 3.9]	3.7 [3.6, 3.8]	3.0 [2.9, 3.1]	2.9 [2.8, 2.9]	3.0 [3.0, 3.1]	.02	< .001

Table 3: Continued

Dietary treatment†	Reproductive cycle						P†	
	Day 50			Day 140			Zn	Cycle
	0	50	100	0	50	100		
Horn growth and wear (mm)								
Horn growth	12.4 [12.0, 12.8]	12.7 [12.3, 13.1]	12.3 [11.9, 12.6]	20.9 [20.3, 21.4]	20.8 [20.2, 21.3]	21.7 [21.2, 22.2]	.67	< .001
Wear rate	16.0 [15.6, 16.5]	17.0 [16.5, 17.5]	16.9 [16.5, 17.4]	16.4 [15.9, 17.0]	16.5 [15.9, 17.1]	17.2 [16.7, 17.8]	.28	.93
Net horn growth§	-3.8 [-4.2, -3.3]	-4.4 [-4.9, -3.9]	-4.7 [-5.1, -4.3]	4.4 [3.9, 4.9]	4.3 [3.8, 4.8]	4.4 [3.9, 4.9]	.55	< .001

- * Mean claw lesion score (mm) is the average score per lesion type for all sows including front and hind claws, lateral and medial digits. Higher values represent worse scores. Mean claw conformation measurements and calculations (mm) is the average score measurement for all sows including front and hind claws, lateral and medial digits. Horn growth and wear (mm) was determined from both lateral and medial claw digits of the left front and right hind claws. Values are mean with [95% CI].
- † There were no interactions between dietary Zn supplementation and floor type or between dietary Zn supplementation and phase within the reproductive cycle, except for sole (base) length. *P* values are presented for the main effect of dietary Zn supplementation (Zn) and for the main effect of phase within the reproductive cycle (Phase). The effect of floor type on claw lesion scores are presented by Bos et al.²⁶ Level of significance is *P* < .05.
- ‡ Dietary treatment is presented as 0, 50, or 100 mg Zn/kg supplemented to the basal diet containing 46.6 mg Zn/kg and 128.9 mg Zn/kg during gestation and lactation, respectively.
- § Net horn growth is horn growth minus wear and represents the balance between horn growth and wear throughout the reproductive cycle.
- ¶ The post-hoc portioned *P* values for sole (base) length are *P* = .34 for day 50 and *P* = .03 for day 140. Differences were observed between the non-supplemented sows and 50 mg/kg supplemented sows.

basal diet during lactation. The impact is, however, not quantifiable. Differences in claw quality for floor type were observed under these similar study conditions, but floor type is documented as an external predisposing factor for claw lesions, whereas dietary Zn concentration may affect claw quality internally^{6,18} by influencing horn production, which may be more time dependent. Therefore, study duration is an important factor to take into account. Claws require a minimum duration for the horn capsule to be produced. In cattle, this was determined as 12 months.^{10,11,20,33} On the basis of the length of the dorsal border and horn growth in the present study, the horn capsule in sows may have been produced in 5 to 6 months. The present study lasted 14.8 months, thus it seems that study duration is unlikely to have influenced the lack of response to Zn observed here.

Claw quality is determined by multiple claw characteristics and depends on an optimal horn production.^{1,2,7,8} In the literature, Zn has been shown to have an important function in horn production.⁷ If Zn supplementation influences horn production, changes in multiple claw quality

measurements should become visible. In the present study, however, only heel horn erosion, heel height, claw volume, toe:heel ratio, and the distance between dermal papillae were influenced. These differences were not linear and not constant between different treatment groups for all characteristics. For instance, the distance between dermal papillae was longer for the 100-mg per kg supplemented sows, indicative of a lower quality of the structure, whereas the heel horn erosion score was better. In accordance with the present study, Anil¹⁷ observed differences only for vertical wall cracks in group-housed sows and only for heel-sole junction lesions in stall-housed sows. Other claw lesion scores assessed in their study were not improved over time. Some differences in claw quality measurements were observed only at day 50 or only at day 140 of the reproductive cycle, suggesting that phase within the reproductive cycle is important for claw quality. This is supported by the substantial fluctuation in net horn growth (horn growth minus wear) between gestation (-4.2 mm between day 140 and day 50, horn wear dominant) and lactation (+4.4 mm between day 50 and day 140, horn growth

dominant). This difference in net horn growth between gestation and lactation can be caused by housing conditions and differences in physiology. Sows were housed in groups for 80 days during gestation and were more able to move around, whereas during lactation the sows were individually housed.

Comparing results of the present study with other studies in sows is difficult, because those studies did not assess the impact of Zn supplementation but did investigate (partially) substituted inorganic Zn, Cu, and Mn sources with organically bound sources at high mineral levels. Similar or better claw lesion scores were reported with organically bound Zn, Cu, and Mn supplementation compared with inorganic sources.¹³⁻¹⁸ Bradley¹⁹ found no difference between mineral sources for claw size and shape, however. Results of the present study do not agree with those of some other studies. This may reflect differences in breeds and test conditions, but also the difference in background levels of Zn in the basal diet. While the results derived from the chosen test conditions in our study should be extrapolated with caution, yet the detail

Table 4: Effect of floor type on mean claw conformation (claw dimensions and calculation) and horn growth and wear* at day 50 and day 140 from sows housed on different floor types during group housing and followed for three reproductive cycles (n = 131 at start of study).

Floor type	Reproductive cycle				<i>P</i> †	
	Day 50		Day 140		Day 50	Day 140
	Concrete	Rubber	Concrete	Rubber		
Claw dimensions (mm)						
Sole (base) length	25.2 [24.9, 25.4]	24.2 [24.0, 24.4]	26.8 [26.5, 27.0]	26.7 [26.4, 27.0]	.19	.94
Claw width	27.8 [27.6, 28.0]	27.3 [27.1, 27.5]	27.4 [27.2, 27.6]	27.4 [27.2, 27.6]	§	§
Length dorsal border	43.0 [42.7, 43.2]	42.6 [42.4, 42.8]	48.8 [48.6, 49.1]	47.5 [47.3, 47.8]	.84	.22
Diagonal claw length	55.3 [54.9, 55.6]	54.8 [54.5, 55.1]	60.0 [59.7, 60.3]	58.7 [58.4, 59.0]	.87	.38
Toe height	36.4 [36.2, 36.6]	34.1 [33.8, 34.3]	35.9 [35.6, 36.2]	36.4 [36.1, 36.7]	.001	.49
Heel height	7.7 [7.4, 8.0]	8.6 [8.3, 8.8]	12.1 [11.8, 12.4]	10.7 [10.4, 11.0]	.056	.04
Claw length	51.2 [50.9, 51.6]	49.1 [48.8, 49.4]	52.3 [51.9, 52.6]	51.5 [51.1, 51.8]	.04	.57
Claw calculations						
Distal toe angle (°)	58.6 [58.1, 59.0]	55.0 [54.3, 55.6]	48.5 [47.9, 49.0]	51.1 [50.6, 51.7]	.04	.16
Sole area (mm ²)	1430 [1413, 1447]	1344 [1330, 1357]	1441 [1424, 1457]	1413 [1398, 1429]	.03	.52
Claw volume (mm ³)	11136 [10709, 11562]	11616 [11203, 12030]	17429 [16969, 17889]	15031 [14530, 15533]	.25	.01
Claw horn size (mm ²)	1543 [1526, 1561]	1502 [1487, 1518]	1654 [1636, 1672]	1612 [1595, 1629]	§	§
Toe:heel ratio	4.1 [3.9, 4.4]	3.5 [3.4, 3.6]	2.9 [2.8, 3.0]	3.1 [3.0, 3.1]	.02	.75
Horn growth and wear (mm)						
Horn growth	13.7 [13.4, 14.0]	11.3 [11.0, 11.6]	21.1 [20.6, 21.6]	21.2 [20.8, 21.6]	.001	.63
Wear rate	17.7 [17.3, 18.0]	15.7 [15.3, 16.1]	16.6 [16.1, 17.1]	16.9 [16.4, 17.3]	.001	.68
Net horn growth‡	-4.1 [-4.4, -3.7]	-4.5 [-4.9, -4.1]	4.5 [4.1, 4.9]	4.3 [3.9, 4.7]	§	§

* Mean claw conformation measurements and calculations (mm) is the average score measurement for all sows including front and hind claws, lateral and medial digits. Horn growth and wear (mm) was determined from both lateral and medial claw digits of the left front and right hind claws. Values are mean with [95% CI].

† There were no interactions between dietary Zn supplementation and floor type, but there were interactions between floor type and phase within the reproductive cycle, except for claw width, claw horn size, and net horn growth. *P* values are presented as post-hoc portioned *P* values for day 50 and day 140. The effect of floor type on claw lesion scores are reported by Bos et al.²⁶ Level of significance is *P* < .05.

‡ Net horn growth is horn growth minus wear and represents the balance between horn growth and wear throughout the reproductive cycle.

§ *P* values for the main effect of floor type for claw width, claw horn size, and net horn growth are *P* = .49, *P* = .31, and *P* = .94, respectively, and for the main effect of phase within the reproductive cycle are *P* = .18, *P* < .001, and *P* < .001, respectively.

Table 5: Effect of dietary Zn supplementation on histological claw characteristics* from sows housed on different floor types during group housing after slaughter at the third reproductive cycle (n = 36)

Histologic characteristics	Dietary treatment (mg Zn/kg)†			Floor type		P‡	
	0	50	100	Concrete	Rubber	Zn	F
Transverse horn wall							
Dermal lamellae (n)	6.6 [5.8, 7.4]	7.4 [6.4, 8.4]	7.0 [6.2, 7.7]	6.9 [6.3, 7.6]	7.0 [6.3, 7.7]	.46	.77
Distance (µm)	153.7 [136.9, 170.5]	139.9 [121.4, 158.4]	145.5 [130.9, 160.1]	146.3 [134.2, 158.4]	146.2 [131.5, 160.9]	.56	.86
Width (µm)	56.4 [47.2, 65.6]	51.9 [39.4, 64.5]	50.0 [43.1, 57.0]	51.9 [45.9, 58.0]	53.6 [44.1, 63.0]	.63	.90
Length (µm)	233.3 [207.0, 259.5]	222.2 [189.3, 255.0]	201.4 [181.4, 221.5]	215.7 [194.2, 237.2]	221.9 [199.7, 244.1]	.35	.77
Sagittal heel horn							
Dermal papillae (n)	3.0 [2.7, 3.3]	2.9 [2.5, 3.3]	2.5 [2.2, 2.9]	3.0 [2.7, 3.3]	2.7 [2.4, 3.0]	.18	.22
Distance (µm)	315.7 ^{ab} [289.3, 342.2]	282.6 ^a [253.5, 311.7]	390.3 ^b [331.9, 448.7]	340.4 [308.7, 372.1]	315.1 [281.8, 348.4]	.004	.04
Width (µm)	126.6 [110.6, 142.6]	131.8 [111.3, 152.3]	150.1 [130.2, 169.9]	130.9 [115.9, 145.9]	137.6 [122.8, 152.3]	.22	.48
Length (µm)	500.0 [386.9, 613.0]	461.3 [364.2, 558.4]	443.7 [370.7, 516.6]	537.7 [438.6, 636.7]	423.6 [363.1, 484.0]	.63	.05
Transverse heel horn							
Horn tubules (n)	7.4 [6.7, 8.0]	6.5 [5.9, 7.1]	6.7 [6.2, 7.2]	6.9 [6.4, 7.4]	6.8 [6.4, 7.2]	.11	.75

* Dermal papillae/lamellae = number of dermal papillae/lamellae per 1000 µm, visible at their full width; Distance = distance between the axis lines of the papillae/lamellae at their base (µm); Width = width of the dermal component halfway and perpendicular to the dermal papillae/lamellae (µm); Length = length of the longest papillae measured from the top of the dermal papillae/lamellae to the origin at the base (µm); Horn tubules = heel horn tubules density expressed as number of horn tubules within a defined surface area of 1 mm². Horn tubules that were only partially visible from two of the four sides of the defined surface area were also included. Values are means with [95% CI].

† Dietary treatment is presented as 0, 50, or 100 mg Zn/kg supplemented to the basal diet containing 46.6 mg Zn/kg and 128.9 mg Zn/kg during gestation and lactation, respectively.

‡ There were no interactions between dietary Zn supplementation and floor type. *P* values are presented for the main effect of dietary Zn supplementation (Zn) and for the main effect of floor type (F). Level of significance is *P* < .05.

^{a,b} Mean values within a row and main effect lacking common superscript letters differ significantly; *P* < .05.

of our measurements, together with the three-cycle duration of the study, rendered important insights that are new to the field. Nevertheless, the type of Zn supplement used may be an interfering factor, as other studies in sows did find positive results of Zn source on claw lesion scores.¹³⁻¹⁷ Perhaps Zn alone does not trigger the processes required to optimise claw quality, and other minerals or dietary components are required as well.

Other studies in sows defined claw quality mainly by claw lesion scores, but claw conformation, horn growth and wear, and mechanical horn characteristics are rarely evaluated. Histological claw characteristics have been assessed more recently.^{3,4} Claw conformation did not differ between

treatment groups except for heel height, claw volume, and toe:heel ratio, which is in accordance with Bradley.¹⁹ Horn growth and wear rate also did not differ in the present study. Lisgara et al¹⁸ also found no effect of partially substituted mineral sources on toe and dewclaw length in one herd, whereas the score did improve over time in each of the other two herds. Herd-specific characteristics might have influenced the outcome in that study. In the same study,¹⁸ claw (front or hind) did interfere with the results. In the present study, horn growth and wear rate differed between front and hind claws as well as for other claw lesion scores and claw conformation. Net horn growth did not differ between

claws, however. There is a need to further determine the impact of these factors. For histological claw characteristics, Varagka et al^{3,4} found that lamellar hyperplasia was most frequently observed and sows had a higher claw lesion score with lamellar hyperplasia. This histological condition is also described in bovine and equine laminitis and may cause low quality horn production. Partially substituting inorganic Zn, Cu, and Mn sources with organic sources resulted in fewer histological changes than in the control group with inorganic mineral sources.³ These interesting findings were deduced from a sample at the dorsal wall halfway between the periople and tip of the toe, whereas in the present study a

Table 6: Effect of dietary Zn supplementation on mechanical horn characteristics* from sows housed on different floor types during group housing after slaughter at the third reproductive cycle (n = 36)

Mechanical characteristics	Test velocity†						P‡	
	1 mm/min			15 mm/min			1	15
Dietary treatment§	0	50	100	0	50	100		
Young's modulus (MPa)	68.3 [60.1, 76.5]	70.2 [59.5, 80.9]	70.0 [61.1, 78.8]	96.6 [86.2, 106.9]	99.2 [84.3, 114.0]	97.0 [85.1, 109.0]	.99	1.00
Yield stress (MPa)	10.8 [9.7, 11.8]	10.5 [9.3, 11.8]	10.1 [9.3, 11.0]	13.1 [11.9, 14.3]	13.5 [12.0, 15.1]	12.9 [11.7, 14.2]	.72	.98
Maximum stress (MPa)	14.8 [13.6, 16.1]	15.3 [13.9, 16.7]	15.1 [13.9, 16.3]	19.5 [18.0, 21.0]	20.2 [18.3, 22.1]	19.7 [18.1, 21.3]	.96	.98
Floor type	Concrete	Rubber	Concrete	Concrete	Rubber			
Young's modulus (MPa)	66.2 [58.5, 73.8]	72.2 [65.1, 79.3]	93.3 [83.1, 103.5]		101.1 [91.6, 110.7]		.74	.73
Yield stress (MPa)	9.9 [9.1, 10.8]	11.0 [10.1, 11.8]	12.6 [11.5, 13.8]		13.6 [12.6, 14.6]		.68	.76
Maximum stress (MPa)	14.8 [13.6, 15.9]	15.3 [14.4, 16.3]	19.4 [18.0, 20.9]		20.0 [18.8, 21.3]		.96	.96

* Young's modulus is a measure of the rigidity and stiffness of the horn; yield stress represents the point on the stress-strain diagram in which the material starts to lose its mechanical function and material properties start to change at further loading, and maximal stress represents the maximum compression (Franck et al.³⁰)

† Mechanical claw characteristics were tested on two test velocity of the right front claw, 1 and 15 mm/min, to test if the abaxial horn wall had visco-elastic properties. The abaxial horn wall does have these properties, because test velocities differ ($P < .05$). Values are means with [95% CI].

‡ There were no interactions between dietary Zn supplementation and floor type. P values are presented for the main effect of dietary Zn supplementation (Zn) and for the main effect of floor type (F) at test velocity 1 mm/min (1) and 15 mm/min (15). Level of significance is $P < .05$.

§ Dietary treatment is presented as 0, 50, or 100 mg Zn/kg supplemented to the basal diet containing 46.6 mg Zn/kg and 128.9 mg Zn/kg during gestation and lactation, respectively.

MPa = MegaPascals

sample from the periople was collected, where horn production is initiated. In the present study, no differences were found in histological characteristics of the horn wall or in mechanical horn strength, although the sample for mechanical horn strength was more closely located to the sample location of Varagka et al.³ Testing for mechanical horn characteristics has not been conducted previously and was based on test conditions used in bovine horn wall without dietary interventions.³⁰ For sows, the extrapolation of this test and its conditions needs to be further explored.

In the present study, most sows had one or more claw lesions, but only the mean heel horn erosion score was better for the 100-mg Zn per kg supplemented sows compared with the non-supplemented sows at day 50 of the reproductive cycle. This result may favor Zn supplementation; however, it is questionable whether the

measured difference is relevant for the sows' welfare and performance and whether this difference is distinguishable during visual claw scoring. Furthermore, it is remarkable that the non-supplemented sows were able to maintain claw quality at the same level as the supplemented sows. While the non-supplemented group had a high background Zn supply during lactation, overall dietary Zn concentration was well below commercial practice and EU regulation of 150 mg per kg total Zn (EU regulation 2016/1095), without negative results, which questions whether the systematic supplementation of Zn, in addition to the amount of Zn (and phytase) present in the basal diet, should be revisited. Further reductions of the EU upper limit for total dietary Zn concentration when using phytase, as suggested by the European Food Safety Authority in 2014, should be tested in relation to claw quality in future studies.

The effect of floor type on claw quality measurements in the present study appeared to be substantial, irrespective of dietary Zn supplementation. Sows housed on a rubber floor had better scores for some claw lesion types, but worse scores for vertical horn wall cracks, white line separation, and overgrown claw at day 50 of gestation, which changed to better scores on rubber at day 140.²⁶ At day 140, scores for white line and claw length were better for sows housed on a rubber floor during gestation.²⁶ Other types of claw lesions did not differ between floor types. This finding is in contrast to results of another study²⁴ in sows that found an increased risk of poor scores for toe overgrowth, heel sole cracks, and horn wall cracks in first-parity sows housed on rubber slat mats, as compared to sows housed on a concrete slatted floor. In the second parity of that study, sows housed on rubber slat mats had an increased risk of poor scores for toe

overgrowth, heel sole cracks, and white line damage.²⁴

Discrepancies between studies may relate to the proportion of solid floor area, as the present study had a higher proportion of solid floor area as compared to a fully slatted floor covered with rubber in the study of Calderón Díaz et al.²⁴ Another explanation may be the quality of the floor as characterised by the slip resistance, abrasiveness, hardness, wear resistance, and age of the floor.⁶ Rubber slat mats may be less abrasive^{24,34} and may be softer than concrete slats.^{24,35-39} The influence of floor type on claw conformation in the present study can be a result of this softer rubber floor. Softer floors can reduce natural horn wear,^{6,40-42} which was also found in the present study in which sows housed on rubber floors had less horn wear at day 50 compared with sows housed on concrete floors. However, some claw lesion scores were lower (better) on rubber. It seems possible that a higher risk for claw lesions does not depend on insufficient wear alone: the balance between horn growth and wear and load bearing (eg, the pressure the floor exerts on the claw and how the load is distributed over the weight-bearing surface) may also be important factors.⁴³ In the present study, horn growth was lower for sows housed on rubber floors at day 50 and net horn growth was not affected, indicating that the balance between horn growth and wear could be maintained and that therefore claws were less prone to develop lesions. Similarly, the distal toe angle was lower on rubber floors, which indicates that there was less wear, less growth, and a smaller sole area.⁴⁴ Load bearing may have been better in the sows housed on rubber floors in the present study, because the histological claw characteristics showed a shortened distance between dermal papillae in the sagittal heel horn, indicating a stronger structure.

Slat properties are also important.^{6,45-47} The rubber top layer in the present study was attached to the concrete floor in a fashion similar to that reported in Calderón Díaz et al.²⁴ One advantage of the rubber top layer may be a reduction in the risk of claws getting entrapped between the slats. An important disadvantage in the study of Calderón Díaz et al.²⁴ was that the manure could not pass through the slats easily. This observation was not included in the present study. Floors covered with liquid and manure have been reported to soften and

irritate the claw, resulting in diminished claw strength.⁶ This may not have been the case in the present study, where moisture content of the horn wall and horn wall strength were not affected by floor type.

In conclusion, no interaction effects between dietary Zn supplementation and floor type were found for claw quality measurements. Dietary Zn supplementation to a typical basal diet had only minor influences on claw quality in sows. Floor type affected multiple claw quality measurements positively. The rubber top layer does improve claw quality and can be implemented for prevention of claw lesions, but more research is warranted. Apart from dietary Zn supplementation and floor type, other factors affected claw quality measurements: differences between lateral and medial claw digits and between front and hind claws were observed, and the reproductive phase had an important effect on claw quality. Worse claw lesion scores were found at day 140, a period in which horn growth dominates and claw conformation characteristics changes, compared with day 50.

Implications

- Dietary Zn supplementation seems not to be the major factor affecting claw quality in the sows in this study.
- Floor type affects claw quality in sows.
- Phase within the reproductive cycle influences claw quality measurements and needs to be considered when claw quality is assessed.

Acknowledgements

This study was supported by the Institute for Promotion of Innovation through Science and Technology in Flanders (IWT, grant number 090938), and co-funded by Orffa, VDV Beton, Boerenbond, AVEVE, INVE, and Boehringer Ingelheim. The authors thank the technicians M. van Yperen and T. Martens, animal caretakers at the ILVO experimental farm, ILVO colleagues and students, J. Buist, J.-M. Muijlaert, laboratory personnel of participating departments, and personnel of the abattoir in Eeklo (Belgium) for their much appreciated assistance and support. Thanks also to M. Levenson for English-language editing.

Conflict of interest

None reported

Disclaimer

Scientific manuscripts published in the *Journal of Swine Health and Production* are peer reviewed. However, information on medications, feed, and management techniques may be specific to the research or commercial situation presented in the manuscript. It is the responsibility of the reader to use information responsibly and in accordance with the rules and regulations governing research or the practice of veterinary medicine in their country or region.

References

1. Politiek RD, Distl O, Fjeldaas T, Heeres J, McDaniel BT, Nielsen E, Peterse DJ, Reurink A, Strandberg P. Importance of claw quality in cattle: review and recommendations to achieve genetic improvement. Report of the EAAP working group on "claw quality in cattle." *Livest Prod Sci.* 1986;15:133-152.
2. Vermunt JJ, Greenough PR. Structural characteristics of the bovine claw: horn growth and wear, horn hardness and claw conformation. *Brit Vet J.* 1995;151:157-180.
3. Varagka N, Lisgara M, Skampardonis V, Psychas V, Leontides L. Partial substitution, with their chelated complexes, of the inorganic zinc, copper and manganese in sow diets reduced the laminitic lesion in the claws and improved the morphometric characteristics of the hoof horn of sows from three Greek herds. *Porcine Health Manag.* 2016;2:26.
4. Varagka N, Lisgara M, Skampardonis V, Psychas V, Leontides L. Pathological evaluation of claw lesions in culled sows from a Greek herd. *J Swine Health Prod.* 2016;24:72-80.
5. Heinonen M, Peltoniemi O, Valros A. Impact of lameness and claw lesions in sows on welfare, health and production. *Livest Sci.* 2013;156:2-9.
6. Pluym L, Van Nuffel A, Maes D. Treatment and prevention of lameness with special emphasis on claw disorders in group-housed sows. *Livest Sci.* 2013;156:36-43.
7. Tomlinson DJ, Mulling CH, Fakler TM. Invited Review: Formation of keratins in the bovine claw: Roles of hormones, minerals, and vitamins in functional claw integrity. *J Dairy Sci.* 2004;87:797-809.
- *8. Muelling CKW. Nutritional influences on horn quality and hoof health. *WCDS Advances in Dairy Technology.* 2009;21:283-291.
9. Enjalbert F, Lebret P, Salat O. Effects of copper, zinc and selenium status on performance and health in commercial dairy and beef herds: retrospective study. *J Anim Physiol Anim Nutr.* 2006;90:459-466.
10. Griffiths LM, Loeffler SH, Socha MT, Tomlinson DJ, Johnson AB. Effects of supplementing complexed zinc, manganese, copper and cobalt on lactation and reproductive performance of intensively grazed lactating dairy cattle on the South Island of New Zealand. *Anim Feed Sci Tech.* 2007;137:69-83.
11. Lethbridge LA. Lameness of dairy cattle: factors affecting the mechanical properties, haemorrhage levels, growth and wear rates of bovine claw horn. PhD dissertation. Massey University, New Zealand. 2009.

12. van Riet MMJ, Janssens GPJ, Cornillie P, Van Den Broeck W, Nalon E, Ampe B, Tuytens FAM, Maes D, Du Laing G, Millet S. Marginal dietary zinc concentration affects claw conformation measurements but not histological claw characteristics in weaned pigs. *Vet J*. 2016;209:98–107.
- *13. Aae H. Danish experience with claw lesions and mineral nutrition. *Zinpro Feet First Symposium*. Minneapolis, Minnesota. 2008;58–63.
- *14. Anil SS, Deen J, Anil L, Baidoo SK, Wilson ME, Ward TL. Analysis of the effect of complex trace minerals on the prevalence of lameness and severity of claw lesions in stall-housed sows. *AD-SA-ASAS Joint Annual Meeting*, Denver, Colorado. 2010;127.
- *15. Anil SS, Deen J, Anil L, Baidoo SK, Wilson ME, Ward TL. Evaluation of the supplementation of complexed trace minerals on the number of claw lesions in breeding sows. *Manipulating Pig Production XII, Australasian Pig Science Association*, Cairns, Australia. 2010;108.
- *16. Da Silva A, Anil SS, Deen J, Baidoo SK. Effect of the supplementation of complexed trace minerals on the healing of claw lesions in two sow herds. *Proc IPVS Cong*. Vancouver, Canada. 2010;1169.
17. Anil SS. Epidemiology of lameness in breeding female pigs. PhD dissertation. University of Minnesota; 2011.
18. Lisgara M, Skampardonis V, Leontides L. Effect of diet supplementation with chelated zinc, copper and manganese on hoof lesions of loose housed sows. *Porcine Health Manag*. 2016;2:6.
19. Bradley CL. Evaluating the impact of dietary inorganic or organic trace mineral supplementation on gilt development and sow reproduction, lameness, and longevity. PhD dissertation. University of Arkansas, Fayetteville, Arkansas; 2010.
20. Hedges VJ, Blowey R, Packington AJ, O'Callaghan CJ, Green LE. A longitudinal field trial of the effect of biotin on lameness in dairy cows. *J Dairy Sci*. 2001;84:1969–1975.
21. Tuytens FAM. The importance of straw for pig and cattle welfare: a review. *Appl Anim Behav Sci*. 2005;92:261–282.
22. Tuytens FAM, Wouters F, Struelens E, Sonck B, Duchateau L. Synthetic lying mats may improve lying comfort of gestating sows. *Appl Anim Behav Sci*. 2008;114:76–85.
23. Elmore MRP, Garner JP, Johnson AK, Richert B. A flooring comparison: The impact of rubber mats on the health, behaviour, and welfare of group-housed sows at breeding. *Appl Anim Behav Sci*. 2010;123:7–15.
24. Calderón Díaz JA, Fahey AG, KilBride AL, Green LE, Boyle LA. Longitudinal study of the effect of rubber slat mats on locomotory ability, body, limb and claw lesions, and dirtiness of group housed sows. *J Anim Sci*. 2013;91:3940–3954.
25. Nalon E, Maes D, Van Dongen S, van Riet MMJ, Janssens GPJ, Millet S, Tuytens FAM. Comparison of the inter- and intra-observer repeatability of three gait scoring scales for sows. *Animal*. 2014;8:650–659.
26. Bos E-J, van Riet MMJ, Maes D, Millet S, Ampe B, Janssens GPJ, Tuytens FAM. Effect of rubber flooring on group-housed sows' gait, claw and skin lesions. *J Anim Sci*. 2016;94:2086–2096.
27. National Research Council. *Nutrient Requirements of Swine*. 11th rev ed. *Natl Acad Press*: Washington DC; 2012.
- *28. Deen J, Schuttert M, van Amstel S, Ossent P, van Barneveld R. Lesion Scoring Guide. In: Feet-First Zinpro Corporation. Eden Prairie, Minnesota; 2009.
29. Calabotta DF, Kornegay ET, Thomas HR, Knight JW, Notter DR, Veit HP. Restricted energy intake and elevated calcium and phosphorus intake for gilts during growth. I. Feedlot performance and foot and leg measurements and scores during growth. *J Anim Sci*. 1982;54:565–575.
30. Franck A, Cocquyt G, Simoens P, De Belie N. Biomechanical properties of bovine claw horn. *Bio-systems Eng*. 2006;93:459–467.
31. ISO 17025. General requirements for the competence of testing and calibration laboratories. International Standards Organization, Geneva, Switzerland; 2005.
32. Van Soest PJ, Robertson JB, Lewis BA. Methods for dietary fiber, neutral detergent fiber, and non-starch polysaccharides in relation to animal nutrition. *J Dairy Sci*. 1991;74:3583–3597.
33. Toni F, Grigoletto L, Rapp CJ, Socha MT, Tomlinson DJ. Effect of replacing dietary inorganic forms of zinc, manganese, and copper with complexed sources on lactation and reproductive performance of dairy cows. *Prof Anim Sci*. 2007;23:409–416.
34. Telezhenko E, Bergsten C, Magnusson M, Ventorp M, Nilsson C. Effect of different flooring systems on weight and pressure distribution on claws of dairy cows. *J Dairy Sci*. 2008;91:1874–1884.
35. Mouttrotou N, Hatchell FM, Green LE. Foot lesions in finishing pigs and their associations with the type of floor. *Vet Rec*. 1999;144:629–632.
36. Scott K, Chennells DJ, Campbell FM, Hunt B, Armstrong D, Taylor L, Gill BP, Edwards SA. The welfare of finishing pigs in two contrasting housing systems: Fully-slatted versus straw-bedded accommodation. *Livest Sci*. 2006;103:104–115.
37. Gillman CE, KilBride AL, Ossent P, Green LE. A cross-sectional study of the prevalence of foot lesions in post-weaning pigs and risk factors associated with floor type on commercial farms in England. *Prev Vet Med*. 2009;91:146–152.
38. KilBride AL, Gillman CE, Ossent P, Green LE. A cross sectional study of prevalence, risk factors, population attributable fractions and pathology for foot and limb lesions in preweaning piglets on commercial farms in England. *BMC Vet Res*. 2009;5:31.
39. KilBride AL, Gillman CE, Green LE. A cross sectional study of the prevalence, risk factors and population attributable fractions for limb and body lesions in lactating sows on commercial farms in England. *BMC Vet Res*. 2009;5:30.
40. McKee CI, Dumelow J. A review of the factors involved in developing effective non-slip floors for pigs. *J Agric Eng Res*. 1995;60:35–42.
41. Kremer PV, Nueske S, Scholz AM, Foerster M. Comparison of claw health and milk yield in dairy cows on elastic or concrete flooring. *J Dairy Sci*. 2007;90:4603–4611.
42. Platz S, Ahrens F, Bahrs E, Nuske S, Erhard MH. Association between floor type and behaviour, skin lesions, and claw dimensions in group-housed fattening bulls. *Prev Vet Med*. 2007;80:209–221.
43. Winkler B. Mechanical properties of hoof horn, sole haemorrhage and lameness in dairy cattle. PhD dissertation. University of Plymouth, United Kingdom; 2005.
- *44. Kroneman A, Vellenga L, Vermeer HM, van der Wilt FJ. Claw health in pigs. Research Report 1.78. Faculty of Veterinary Medicine, Utrecht, The Netherlands. 1992;1–32.
45. Webb NG. Compressive stresses on, and the strength of the inner and outer digits of pigs' feet and the implications for injury and floor design. *J Agric Eng Res*. 1984;30:71–80.
46. Boon CR, Wray C. Building design in relation to the control of diseases of intensively housed livestock. *J Agric Eng Res*. 1989;43:149–161.
47. Anil SS, Anil L, Deen J, Baidoo SK, Walker RD. Factors associated with claw lesions in gestating sows. *Swine Health Prod*. 2007;15:78–83.

* Non-refereed references.



Nursery pig behavior evaluation pre- and post injection using digital-image methodology

Shawna L. Weimer, MS; Thomas J. Fangman, DVM, MS, Dipolmate ABVP; Locke A. Karriker, DVM, MS, Diplomate ACVPM; Kenneth J. Stalder, PhD; Anna K. Johnson, PhD

Summary

Objectives: To determine if nursery pigs display different behaviors and postures pre- and post injection during the human-approach paradigm using a digital photographic image.

Materials and methods: A digital camera captured an image of nursery pigs in a pen during a human-approach paradigm at two time points, pre- and post injection, with three different treatments. A total of 149 pens containing crossbred, mixed-sexed nursery pigs 42 days of age were used. Each pen of pigs was randomly assigned to one of three injection treatments: Vaccine A (saline administered on day 28 and Vaccine A on

day 43); Vaccine B (vaccine administered days 28 and 43); and saline (VSAL; saline administered on days 28 and 43). All pigs were classified as Touched, Oriented, or Not Oriented. Pigs classified as Not-Oriented were further delineated into four postures and two behaviors. Within behavioral categories, snout and tail-base distances from the human were measured.

Results: There were no pre-injection pen behavioral differences. Fewer Vaccine B-treated pens were classified as Touched compared to Vaccine A- and VSAL-treated pens. Regardless of treatment, more pigs were Not Oriented post injection than pre-injection. Fewer Vaccine B-treated pigs stood than did

other treatments. Vaccine B-treated pigs had the greatest snout and tail-base distances from the human.

Implication: It is important to establish the age of the nursery pigs and the vaccine with which they are treated when conducting an on-farm assessment using a human-approach paradigm.

Keywords: swine, human-approach paradigm, injection, behavior

Received: April 29, 2017

Accepted: September 6, 2017

Resumen - Evaluación de la conducta de cerdos en destete pre y post inyección utilizando una metodología de imagen digital

Objetivos: Determinar si los cerdos en destete exhiben diferentes conductas y posturas pre y post inyección durante el paradigma de acercamiento humano utilizando una imagen fotográfica digital.

Materiales y métodos: Una cámara digital capturó una imagen de cerdos de destete en corral durante el paradigma de acercamiento humano en dos momentos: pre y post inyección, con tres tratamientos diferentes. Se utilizaron un total de 149 corrales que contenían cerdos de destete, híbridos, de ambos sexos, de 42 días de edad. Cada corral de cerdos se asignó aleatoriamente

a uno de tres tratamientos de inyección: Vacuna A (solución salina administrada en el día 28 y Vacuna A en el día 43); Vacuna B (vacuna administrada en los días 28 y 43); y solución salina (VSAL [por sus siglas en inglés]; solución salina en los días 28 y 43). Todos los cerdos fueron clasificados como Tocados, Orientados, o No Orientados. Los cerdos clasificados como No Orientados se definieron en cuatro posturas y dos conductas. Dentro de las categorías conductuales, se midió la distancia entre el hocico y la base de la cola, y el humano.

Resultados: No hubo diferencias conductuales de corral pre inyección. Se clasificaron menos corrales tratados con la Vacuna B como Tocados comparado contra los

corrales tratados con la Vacuna A y VSAL. Independientemente del tratamiento, hubo más cerdos No Orientados post inyección que pre inyección. Menos cerdos tratados con la Vacuna B permanecieron quietos que en los otros tratamientos. Los cerdos tratados con la Vacuna B presentaron la mayor distancia entre el hocico y la base de la cola y el humano.

Implicaciones: Es importante establecer la edad de los cerdos en destete y la vacuna con la que son tratados cuando se realiza una valoración en granja utilizando un paradigma de acercamiento humano.

Résumé - Évaluation des porcelets en pouponnière pré- et post-injection à l'aide d'une méthodologie par image digitale

Objectifs: Déterminer si des porcelets en pouponnière démontrent des comportements différents ainsi que leur posture pré- et post-injection durant le paradigme d'une approche humaine à l'aide d'images photographiques digitales.

Matériels et méthodes: Une caméra digitale enregistra une image de porcelets en pouponnière dans un enclos durant un paradigme d'une approche humaine à deux

SLW, AKJ, KJS: College of Agriculture and Life Sciences, Iowa State University, Ames, Iowa.

LAK: Swine Medicine Education Center, College of Veterinary Medicine, Iowa State University, Ames, Iowa.

TJF: Boehringer Ingelheim Vetmedica Inc, St Joseph, Missouri.

Corresponding author: Dr Anna K. Johnson, 2356-F Kildee Hall, Department of Animal Science, Ames, IA 50011; Tel: 515-294-2098; Fax: 515-294-4473; E-mail: johnsona@iastate.edu.

This article is available online at <http://www.aasv.org/shap.html>.

Weimer SL, Fangman TJ, Karriker LA, et al. Nursery pig behavior evaluation pre- and post injection using digital-image methodology. *J Swine Health Prod.* 2018;26(1):25–33.

moments dans le temps: pré- et post-injection, avec trois traitements différents. Au total, 149 enclos hébergeant des porcelets en pouponnière de race croisée, appartenant aux deux sexes et âgés de 42 jours ont été utilisés. Chaque enclos de porcelets a été assigné au hasard à l'un des trois traitements par injection: Vaccin A (saline administrée au jour 28 et Vaccin A au jour 43); Vaccin B (vaccin administré aux jours 28 et 43); et saline (VSAL; saline administrée aux jours 28 et 43). Tous les porcs ont été classés en tant que Touché, Orienté, ou Non-Orienté. Les animaux classés comme Non-Orienté ont subséquemment été définis selon quatre postures et deux comportements. À l'intérieur des catégories de comportement, les distances du groin et de la base de la queue par rapport à un humain ont été mesurées.

Résultats: Il n'y avait pas de différence dans le comportement pré-injection parmi les enclos. Moins d'enclos parmi le groupe Vaccin B furent classés comme Touché comparativement à ceux des groupes Vaccin A et VSAL. Indépendamment du traitement, plus de porcelets étaient Non-Orienté post-injection que pré-injection. Moins de porcelets du groupe Vaccin B se tenaient debout comparativement aux autres traitements. Les porcelets du groupe Vaccin B avaient les plus grandes distances du groin et de la base de la queue par rapport à l'humain.

Implication: Il est important d'établir l'âge des porcelets en pouponnière et le vaccin avec lequel ils seront traités lorsque l'on mène une évaluation sur la ferme en utilisant le paradigme d'une approche humaine.

On-farm welfare assessments and third-party audits are carried out to document compliance with animal care and welfare policies and procedures.¹ Welfare assessment and audit criteria can be divided into resource- and animal-based measures. One animal-based measure is the human-approach paradigm (HAP). The aim of this paradigm is to determine the animal-human relationship, ie, positive, neutral, or negative. The Welfare Quality Assurance program assesses this paradigm;² however, the Pork Quality Assurance Plus (PQA-Plus) Program and the Common Swine Industry Audit (CSIA) describe the importance of pig-human interactions, but do not formally assess or audit the paradigm.³ The predecessor to PQA-Plus, SWAP (Swine Well-being Assurance Program), did include a HAP. When assessed for validity, the HAP

was amended to be a bench-marking evaluation instead of a required assessment due to inconsistent repeatability attributed to differing production strategies. Preliminary work using the HAP noted that nursery pigs recently vaccinated with porcine circovirus type 2 (PCV2) were reluctant to approach a human in their home pen.⁴ Vaccines are extremely important to protect pig health and improve welfare, but pigs not approaching the human because they were recently injected (vaccinated) could be misinterpreted as being poorly handled. The method of collecting information during the HAP is also an important consideration. Previous work by Weimer et al¹ compared live observation to a digital photographic image. The major benefit of a digital photographic image is the infinite amount of time available for retrospective analysis. Hence, if we could determine the nursery pig's behavioral changes pre- and post injection during the HAP using a digital photographic image, this may better define the effect of vaccination to support conclusions based on behavior. Therefore, the objective of this study was to determine if nursery pigs display different behaviors and postures pre- and post injection during the HAP recorded using digital photographic images.

Materials and methods

All procedures were approved by the Iowa State University Animal Care and Use Committee.

Animal care and husbandry protocols for this experiment were overseen by the company veterinarian and farm manager. These protocols were based on the US swine industry guidelines presented in the Pork Quality Assurance Plus.³

Animals

The experiment was conducted in November 2011 at a commercial nursery site located in South Central Missouri. Crossbred PIC barrows and gilts (housed in mixed pens) were 42 days of age and weighed approximately 12 kg when the experiment began. Pigs were not individually weighed before the experiment.

Housing and management

A total of 149 pens (averaging 20 pigs per pen, 2991 pigs total) distributed in four rooms were used in this study. Rooms measured 34.1 m width × 18.3 m length, and

ceiling height was 2.1 m. Pens measured 1.8 m width × 3 m length, providing 0.3 m² per pig, and all pens had woven wire flooring (3-gauge Boss Hog; J & L Wire, St Paul, Minnesota). A stainless steel rectangular feeder (Automated Production Systems, Assumption, Illinois) was located either on the right or left side of the pen. Pigs were provided ad libitum access to a pelleted diet (1549 kcal per kg metabolizable energy and 22% crude protein) formulated to meet or exceed National Research Council nutrient requirements by each nursery phase.⁵ Each pen contained one stainless steel nipple drinker (Drik-O-Mat; Egebjerg, Denmark). Fifteen incandescent lights were turned on at 8:00 AM for daily chores and then were turned off at 11:00 PM. Rooms were mechanically ventilated with a curtain system, two stir fans, 10 inlets, and two heaters (Re-Verber-Ray; Detroit Radiant Products Company, Warren, Michigan). Daily temperatures were recorded using data loggers (HOBO H08-003-02; Onset Data Loggers, Bourne, Massachusetts). Caretakers observed all pigs twice daily.

Injection treatment

The pen-applied injection treatments were Ingelvac CircoFLEX-Ingelvac MycoFLEX vaccine (Vaccine A; Boehringer Ingelheim Vetmedica Inc, St Joseph, Missouri); Circumvent PCVM vaccine (Vaccine B; Merck, Kenilworth, New Jersey); and Saline (VSAL; Hyclone Phosphate Buffered Saline; Sigma Aldrich, St Louis, Missouri).

Experimental design

The experimental unit was the pen of pigs and an entire pen of pigs received the same injection treatment. Injection treatments applied to each pen were completely randomized and blocked within four rooms so that injection order did not affect the behavioral outcomes. On arrival at the nursery (28 days of age), pigs given Vaccine B received their first Vaccine B dose. Pigs assigned the Vaccine A treatment received saline. Pigs assigned the VSAL treatment received Vaccine A (the farm's health program required pigs to have vaccination coverage; Table 1). When pigs were 42 days of age, pig behavior was collected at 4:00 PM (pre-injection). At 43 days of age, pigs were given their assigned second injection treatment beginning at 10:00 AM, and then behavior was collected beginning at 4:00 PM (post injection).

Table 1: Injection treatments given to nursery pigs in a study of behavioral changes pre- and post injection*

Age (days)	Injection treatment†		
	Vaccine A	Vaccine B	VSAL
28	VSAL	Vaccine B	Vaccine A
43	Vaccine A	Vaccine B	VSAL

* Commercial pens measuring 1.8 m width × 3 m length provided 0.3 m² space per pig. PIC barrows and gilts (housed in mixed pens) were administered the first injection treatment at 28 days of age. When pigs were 42 days of age, behavior was collected at 4:00 PM (pre-injection). At 43 days of age, pigs were given their second assigned injection treatment beginning at 10:00 AM, and then behavior was collected beginning at 4:00 PM (post injection).

† Pens of pigs were treated either with Vaccine A (CircoFLEX/MycroFLEX 2-mL dose; Boehringer Ingelheim Vetmedica, Inc, St Joseph, Missouri; n = 48 pens), or Vaccine B (Circumvent-PCVM 2-mL dose; Merck, Whitehouse Station, New Jersey; n = 51 pens), or phosphate buffered saline (Hyclone Phosphate Buffered Saline 2-mL dose; Sigma Aldrich, St Louis, Missouri; VSAL; n = 50 pens), each administered as a single intramuscular dose injected into the right lateral cervical musculature using a 16-gauge needle.

Injection methodology

Pigs were moved towards the alley end of their home pen by the farm manager using a sort board. Pigs were not picked up and individually handled in an effort to avoid any additional handling stressors.^{6,7} The site owner-manager and the pig owner administered the preset dose using a Uni-Matic 2-mL, multi-dose syringe (approximately 1 second per pig) into the lateral cervical musculature on the right side of the neck using a 16-gauge, 1.6-cm length needle (Air-Tite Products Co Inc, Virginia Beach, Virginia). To avoid injecting the same pig twice, a mark was placed between the pig's scapulas using an animal-safe crayon after injection (Raidex Animal Marking Sticks; Thousand Hill Supply, Walworth, New York). The same personnel performed injection treatments for all pigs. Injection treatments were administered to pigs within pens in an alternating fashion across the alleyway.

Digital photograph system

The digital photograph system was constructed using similar methods to those previously described by Weimer et al.¹ Briefly, the digital photograph system was free standing and positioned in the alleyway at the midpoint of the adjacent front pen gate where there were no feeder obstructions, and the image captured the entire nursery pen (Figure 1). The camera (Pentax Optio W90 model; Pentax Imaging Company, Golden, Colorado) was equipped with an infrared wireless shutter remote control (Pentax Imaging Company) to record the images while the observer was in the nursery pen. The camera focal length was 28 mm, with a 3-megapixel resolution.

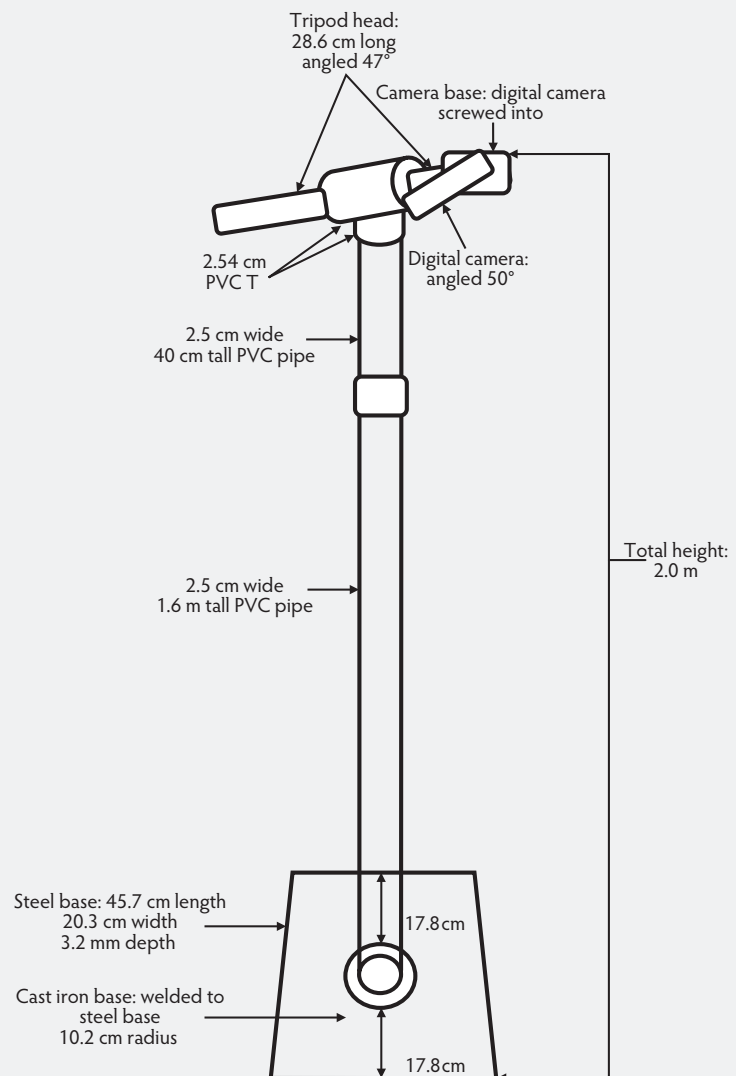
Figure 1: Digital photograph system schematic used to capture the pig images within each pen (1.8 m width × 3 m length).

Human-approach paradigm

The HAP (Figure 2) was applied to pens in the order that injection treatments were administered. Upon entry into the room, the observer and digital photograph system operator walked down the length of the nursery room to the farthest pen. The observer positioned the digital photograph system at the midpoint of the adjacent pen front gate. The observer stepped over the gate and entered the nursery pen, immediately crouching with head down at gate center. Simultaneously, the digital photograph system operator sat on a bucket in the alleyway, directly behind the crouched observer, and leaned back on the gate. The observer extended and held still the left leather-gloved hand with the index finger extended, and began a stopwatch, avoiding eye contact with pigs for 15 seconds. The left hand and finger were extended to allow the same anatomical location to be clearly visible on each digital image. At the end of the 15 seconds, the observer signaled to the digital photograph system operator by leaning back against the gate, and the system operator captured an image of the pen using a wireless remote. The HAP methodology was completed quietly, with no talking between the observer and the digital photograph system operator.

Behavior classification

The same observer that conducted the HAP on-farm in each pen also analyzed each digital image taken by the digital image photography system operator. The observer was blinded to vaccine treatments until all images had been analyzed. Within each digital image of individual pens, all pigs were classified into three categories, Touched, Oriented, or Not Oriented, at the ISU-Animal Behavior Laboratory using Adobe Photoshop CS5 (Adobe Systems Inc, San Jose, California; Figure 2). Not Oriented pigs were further classified into four mutually exclusive postures or two behaviors (Table 2).

For both pre- and post injection treatments, pig percentages for Touched, Oriented, and Not Oriented categories were calculated as $[\text{No. of pigs categorized as Touched or Oriented or Not Oriented in the pen} \div \text{Total no. of pigs in the pen}] \times 100$.

For both pre- and post injection treatments, pig percentages for further delineating Not Oriented postures or behaviors (standing, sitting, piling, lying, head in feeder, and

Figure 2: Examples of nursery pigs classified as Touched (numbers 1, 2, 3, 4, and 5), Oriented (numbers 8, 9, and 10), and Not Oriented (numbers 6, 7, 11, 12, 13, 14, 15, 16, 17, 18, 19, 20, and 21). The observer positioned the digital photograph system at the midpoint of each pen gate in the alleyway. The HAP was performed on each pen of pigs by the observer stepping into the pen and immediately crouching with head down at the center of the gate. The digital photograph system operator sat on a bucket on the opposite side of the gate. The observer extended and held still the left hand for 15 seconds. After 15 seconds, the observer signaled to the digital photograph system operator by leaning against the front gate, at which point the digital image of the pen was captured.



mouth around drinker) were calculated as $[\text{No. of pigs categorized in further delineated Not Oriented postures or behaviors in the pen} \div \text{Total no. of pigs categorized as Not Oriented in the pen}] \times 100$.

The percentage difference was calculated by subtracting the post injection percentage of pigs from the pre-injection percentage of pigs categorized as Touched, Oriented, Not Oriented, and Not Oriented further delineated postures or behaviors.

Snout and tail-base distance. Distance (cm) from the human observer's left index finger in the pen to the snout and tail-base

of each pig was measured using the digital image (Figure 2). Snout and tail-base anatomical locations were chosen from previous work conducted by Weimer et al.¹ Snout was defined as the midpoint of the superior snout, and tail-base was defined as the point of the pig's superior rear located at the tail-base. If a pig snout or tail-base was not visible in the digital image, the distance was excluded from the final data set. Snout and tail-base proximities were measured using the ruler tool in Adobe Photoshop CS5 (Adobe Systems Inc). To determine the actual snout distance, lengths collected from the digital image using the Adobe ruler were converted

Table 2: Nursery pig behavior classification using a digital image analysis at the conclusion of a human approach paradigm (HAP)*

Measure	Definition
Touched	Any part of the pig's body touching the human observer.
Oriented	Pig Oriented toward the human. Using Adobe Photoshop (Adobe Systems Incorporated, Arden Hills, Minnesota), in the digital image, a line was drawn from the midpoint between the pig's eyes to the center of the snout and extended towards the edge of the pen. If the line intersected with the human, the pig was classified as Oriented.
Not Oriented	Pigs not exhibiting the above two behavioral classifications.
Standing	Upright position with all four feet on the floor
Sitting	Hind legs and buttocks touching the floor
Piling	Two or more feet off the floor with body atop a pen mate
Lying	Sternal or lateral body contact with the floor
Head in feeder	Pig's head is inside the feed trough
Mouth around drinker	Pig's mouth encircles the nipple drinker

* Ethogram based on Weimer et al.¹

using the actual length of the nursery feeder (90.4 cm) and the feeder radius in pixels (620 pixels) for the digital image. The nursery feeder in the image was chosen as the calibration focus for the ruler tool because it was always visible and consistently the same length in each pen. The conversion ratio was 6.9 (620 pixels ÷ 90.4 cm = 6.9). It was possible to collect 2863 of 5982 total snout and tail-base distance measures.

Statistical analysis. All data were analyzed using SAS software version 9.3 (SAS Institute Inc; 2011). The three behavioral categories (Touched, Oriented, and Not Oriented), the Not Oriented postures and behaviors, and the snout and tail-base distance to the observer's index finger were analyzed for normal distribution before analysis with PROC UNIVARIATE. The treatment comparisons pre- and post injection, as well as the differences (calculated by subtracting the post injection percentage of pigs from the pre-injection percentage), within behavioral categories were not normally distributed and hence data were analyzed using a generalized mixed linear model (PROC GLIMMIX). The snout and tail-base distances to the observer's index finger were normally distributed and were analyzed using a mixed linear model (PROC MIXED). For both models, the fixed effect of injection treatment (Vaccine A, Vaccine B, and VSAL), with the random effects of pen nested within room were used. A value of

$P < .05$ was considered significant and differences between means were detected using PDIFF.

Results

Behavior

There were no pre-injection treatment differences for Touched, Oriented, and Not Oriented ($P \geq .22$). Post injection, fewer Vaccine B-injected pens of pigs were classified as Touched compared to Vaccine A and VSAL-injected pens ($P < .001$). More pens of saline-injected pigs were classified as Oriented compared to pens of Vaccine A- and Vaccine B-injected pigs ($P < .001$; Table 3). When comparing pen pre- and post injection differences, fewer Vaccine B pigs were classified as Touched (-6.9%; $P < .05$; Figure 3). All pen-applied injection treatments had fewer pigs classified as Oriented (range -0.3% to -10%; $P < .05$; Figure 3) post injection. There was a 17% average pen increase for Vaccine B-injected pigs classified as Not Oriented ($P < .05$; Figure 3). There were no pre-injection treatment differences observed for the percentages of pigs within each pen classified as standing, sitting, piling, lying, head in feeder, and mouth around drinker ($P > .05$; Figure 4). Post injection, there were fewer Vaccine B-injected pens of pigs classified as standing ($P < .001$), but more were classified as sitting ($P < .001$) and lying ($P < .01$) compared to pens receiving Vaccine A and VSAL injection treatments

(Table 4). Regardless of injection treatment, the pre- and post injection differences resulted in more pigs classified as lying and fewer standing within each pen ($P < .05$; Figure 4).

Snout and tail-base distance

There were no pre-injection differences observed for snout and tail-base distances between pen treatment groups for pigs classified as Touched, Oriented, or Not Oriented ($P \geq .13$). Post injection, there were no injection treatment differences for the snout or tail-base average distances in the Touched and Not Oriented categories ($P \geq .10$). However, the average distances between the pigs' snout and tail-base in relation to the observer's left index finger were shorter for pens that received the Vaccine A injection treatment ($P < .05$) than for pens that received the Vaccine B treatment in the Oriented category (Table 5).

Discussion

In 2004, porcine circovirus disease (PCVD) emerged.⁸ When commercial pigs were exposed to this viral pathogen, mortalities were reported at over 20%. By 2006, two vaccination products were available: Suvaxyn, (Fort Dodge Animal Health, Fort Dodge, Iowa) a chimera product, and Circumvent PCV2, (Merck, Kenilworth, New Jersey), a subunit vaccine. Swine producers observed a transient behavioral change among pigs treated with the PCV2 vaccines,

Table 3: Behavioral pen mean percentages (\pm SE) of commercial nursery pigs in a human approach paradigm (HAP) classified as Touched, Oriented, or Not Oriented pre- and post injection*

No. of pens	Injection treatment			P
	Vaccine A 48	Vaccine B 51	VSAL 50	
Pre-injection				
Touched†	9.8 \pm 1.0	12.0 \pm 1.6	10.0 \pm 1.2	.54
Oriented	32.8 \pm 1.8	34.5 \pm 1.8	33.5 \pm 1.8	.80
Not Oriented	57.3 \pm 1.6	53.5 \pm 1.6	56.6 \pm 1.6	.22
Post injection				
Touched	11.3 \pm 1.2 ^a	5.1 \pm 1.5 ^b	13.1 \pm 1.5 ^a	< .001
Oriented	27.8 \pm 1.5 ^b	24.4 \pm 1.5 ^b	33.2 \pm 1.5 ^a	< .001
Not Oriented	60.9 \pm 1.7 ^b	70.5 \pm 1.7 ^a	53.7 \pm 1.7 ^c	< .001

* Vaccines and schedules described in Table 1.

† Ethogram of behaviors described in Table 2.

^{abc} Means within a row with no common superscript are significantly different (LS Means; $P < .05$).

Figure 3: Behavioral pen mean percentage (\pm SE) differences (calculated by subtracting the post-injection percentage of pigs from the pre-injection percentage of pigs) for commercial nursery pigs classified as Touched, Oriented, and Not Oriented (behaviors described in Table 2) using a digital image at the conclusion of the human approach paradigm (HAP; methodology described in Figure 2) pre- and post injection (vaccines and schedules described in Table 1). Means were compared within a behavior category. Means with no common superscript (^{abc}) are significantly different (LS Means, $P < .05$).

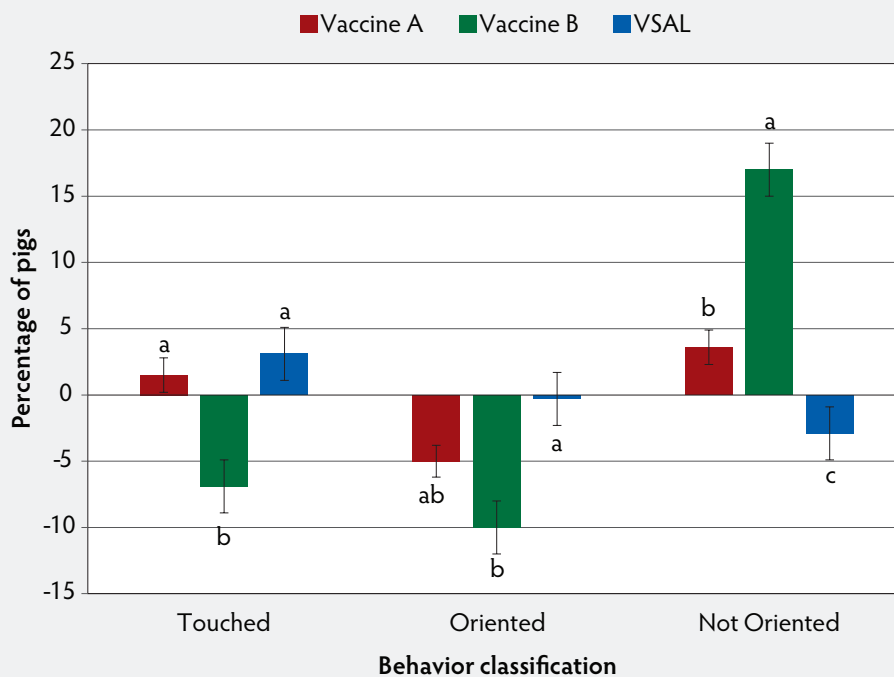

with more pigs lying approximately 6 hours after vaccination. In 2007, CircoFLEX, (Boehringer Ingelheim Vetmedica Inc, St Joseph, Missouri) a PCV2 subunit vaccine, was released.⁹

To quantify the transient behavioral differences noted in pigs after treatment with these vaccines, the authors chose the HAP.¹⁰⁻¹³ All mammals display similar physiological alterations (ie, febrile response) and sickness behaviors (lethargy, decreased appetite and thirst, huddling, shivering, sleepiness, reduced grooming and exploration, uncoordinated body movements, and an increase in pain sensitivity)^{14,15} to bacterial, viral, and protozoan pathogens. These alterations and sickness behaviors are derived from the energy cost diverted to the physiological response to an immunogen, subsequent antibody formation, and memory-cell development and nourishment.

The present study agrees with the injection effect on pig behavior, where a greater percentage of pigs within pens that received a vaccine injection were classified as Not Oriented 6 hours post injection. The purpose of the saline (VSAL) injection was to control for variation due to restraint handling and injection experience.^{16,17} Additionally, due to the dosage timeline differences of Vaccine B being a two-stage vaccine and Vaccine A being a one-stage vaccine, Vaccine A pens of pigs received a saline injection, whereas Vaccine B pens of pigs received the Vaccine B injection on day 28 of age. Therefore, the post-vaccination differences may have been due to the vaccine complexities. Relatedly, pens of

Figure 4: Postural mean percentage (\pm SE) differences (calculated by subtracting the post-injection percentage of pigs from the pre-injection percentage of pigs) for commercial nursery pigs within each pen further delineated into Not Oriented posture and behavior categories (behaviors and postures described in Table 2) using a digital image methodology at the conclusion of the human approach paradigm (HAP; methodology described in Figure 2) pre- and post injection (vaccines and injection schedules described in Table 1). Means were compared within a behavior category. Means with no common superscript (^{ab}) are significantly different (LS Means; $P < .05$).

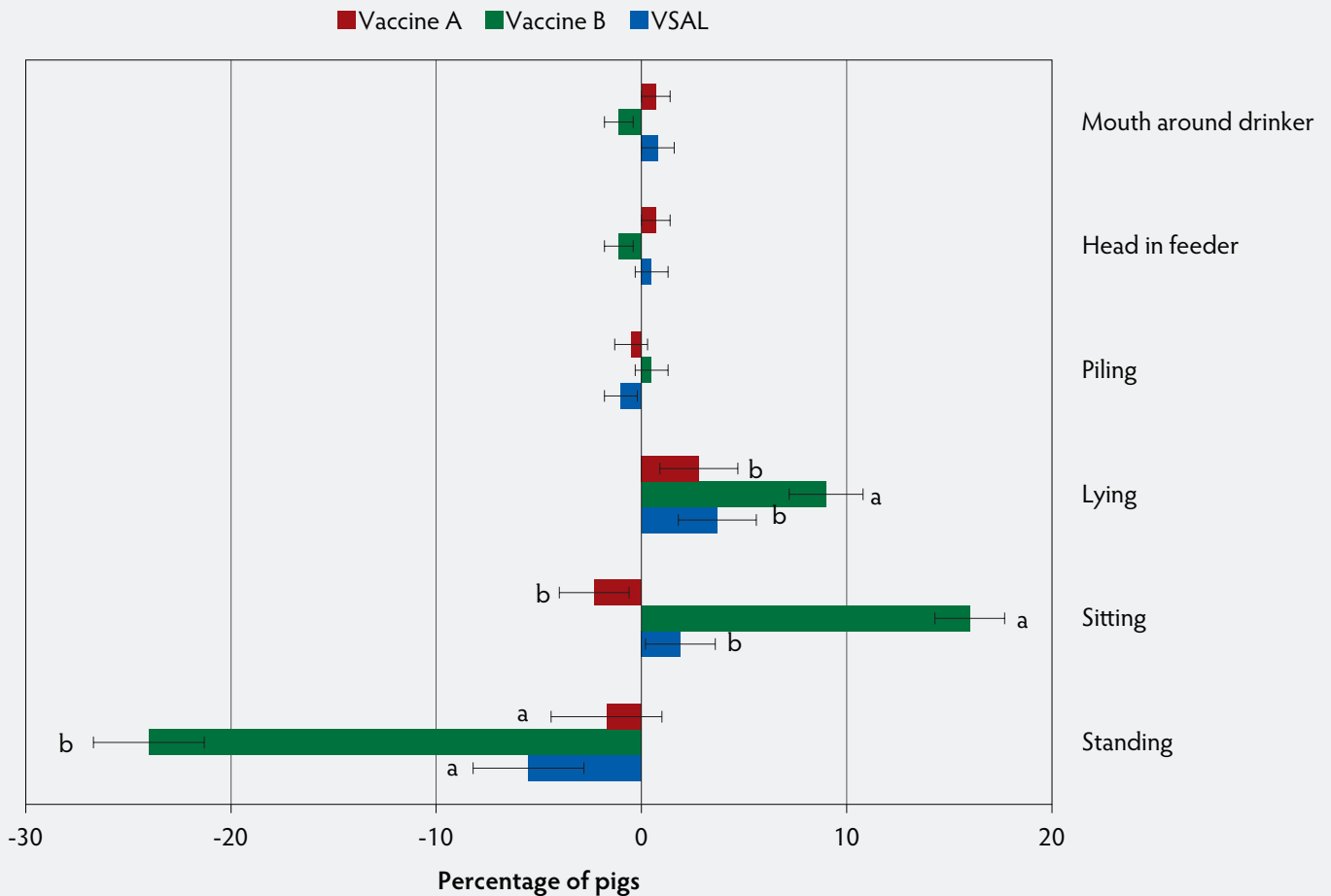

pigs injected with Vaccine A may have not responded to the adjuvant at 6 hours and HAP reactivities may have increased after 6 hours. The increase in pig approachability post injection from VSAL-treated pens may be an indicator that the injection procedure itself is not a stressor. Conversely, pens of pigs treated with Vaccine B had the greatest average decrease in pigs classified as standing (24%) and the greatest average increase of pigs sitting (16%). The results indicate the Vaccine B vaccine may have induced a stronger innate immune response. However, regardless of vaccine, this study notes that the majority of pigs post injection assumed a lying posture. Few pens had pigs pre- and post injection that piled, which has been interpreted as a fear behavior.^{18,19}

Fangman et al¹¹ used the HAP method to compare pre- and post injection nursery pig

behavior within pens vaccinated with Ingelvac MycoFLEX (Boehringer Ingelheim Vetmedica Inc, St Joseph, Missouri) and RespiSure-One (Pfizer Animal Health, Exton, Pennsylvania). Pens of pigs vaccinated with RespiSure-One were less willing to approach the observer than pens of pigs vaccinated with Ingelvac MycoFLEX 6 hours post injection. Similarly, Bretey et al¹² measured pig latency to approach pre- and 6 hours post injection within the pen after vaccination with Ingelvac CircoFLEX (Boehringer Ingelheim Vetmedica Inc, St Joseph, Missouri), Ingelvac MycoFLEX, an Ingelvac CircoFLEX-Ingelvac MycoFLEX mixture (Vaccine A; (Boehringer Ingelheim Vetmedica Inc, St Joseph, Missouri), a Circumvent/M Plus Pac mixture (Merck, Kenilworth, New Jersey), and saline. The pens given CV-MP had the fewest pigs willing to approach the observer

post injection (25.3 %) compared to pens injected with saline (9.6 %), Ingelvac MycoFLEX (12.3 %), and Ingelvac CircoFLEX (9.5%). Therefore, these studies suggest multi-dose exposures to vaccine adjuvants may elicit more rapid immune responses than do single-dose exposures.

There were no pre-injection behavior differences between treatment groups for average pen snout and tail-base distances from the observer. Post injection, average pig tail-base distances within each pen were closer to the human observer in the Vaccine A-treated pens than in the Vaccine B and VSAL treated pens. This result is difficult to interpret practically. Using tail and snout distances did not provide clear conclusions on any injection effects in nursery pigs. It is interesting to note that more anatomical locations were unobservable post injection.

Table 4: Behavioral pen mean percentages (\pm SE) of commercial nursery pig postures and behaviors when classified as Not Oriented in a human approach paradigm (HAP) pre- and post injection*

No. of pens	Injection treatment			P
	Vaccine A 48	Vaccine B 51	VSAL 50	
Pre-injection				
Standing†	81.2 \pm 2.3	83.0 \pm 2.2	86.3 \pm 2.3	.28
Sitting	6.5 \pm 1.2	3.8 \pm 1.2	5.7 \pm 1.2	.25
Piling	2.4 \pm 0.7	1.4 \pm 0.7	1.2 \pm 0.7	.47
Lying	7.2 \pm 1.7	8.5 \pm 1.6	4.3 \pm 1.6	.17
Head in feeder	1.6 \pm 0.6	1.5 \pm 0.5	1.2 \pm 0.6	.90
Mouth around drinker	1.0 \pm 0.5	1.9 \pm 0.5	1.2 \pm 0.5	.48
Post injection				
Standing	79.5 \pm 2.8 ^a	59.0 \pm 2.7 ^b	80.8 \pm 2.7 ^a	< .001
Sitting	4.2 \pm 1.6 ^b	20.4 \pm 1.5 ^a	7.7 \pm 1.6 ^b	< .001
Piling	1.4 \pm 0.6	1.9 \pm 0.5	0.8 \pm 0.6	.34
Lying	10.9 \pm 2.0 ^b	17.5 \pm 2.0 ^a	7.1 \pm 2.0 ^b	< .01
Head in feeder	2.3 \pm 0.6 ^a	0.4 \pm 0.6 ^b	1.7 \pm 0.6 ^{ab}	< .10
Mouth around drinker	1.7 \pm 0.5	0.8 \pm 0.5	2.0 \pm 0.5	.22

* Vaccines and schedules described in Table 1.

† Ethogram of behaviors and postures described in Table 2.

^{ab} Means within a row with no common superscript are significantly different (LS Means; $P < .05$).

Possible explanations could be related to head position within the pen (more post-injection pigs holding their heads in a downward position). Another explanation is that pigs may have been closer together and thus anatomical locations were obstructed from view. Therefore, it is suggested that future work should include pig-to-pig distance and head position in relation to the body. In addition, it may be useful to conduct the HAP at additional time points after 6 hours post injection to determine when vaccination effects, if any, disappear. Additional work should include injection treatments at different production phases.

If this study were repeated, several additional measures could be included. First, a control group where pigs are not handled, as well as a group of pigs that are handled but not vaccinated, might be included in combination with injection treatments. This would help researchers more clearly identify the portion of the vaccination process (ie, pig handling, injection, or the immunogen) that may negatively impact pig behavior to the greatest degree. Secondly, the HAP would be conducted at later time points to determine when pigs return to baseline HAP

values. This would help determine the length of time pigs exhibit lethargic behaviors post vaccination. In addition, physiological and performance measures such as serum cortisol, core body temperature, and feed intake would be useful to correlate with HAP to interpret the underlying mechanisms responsible for the altered behavior.

Implications

- Under the conditions of this study, pens of pigs orient less towards the human 6 hours after injection.
- Under the conditions of this study, when delineating post-injection behaviors and postures, vaccinated pens of pigs are categorized as displaying more lying behavior.
- Differences may exist in behavioral reactivities to vaccine injections.
- If the HAP were to be incorporated in an on-farm welfare assessment or auditing program, it would be important to know the age of the nursery pigs and the vaccine with which they are treated, and the protocol should be provided to accurately determine pig welfare.

Acknowledgements

This work was supported by Boehringer Ingelheim Vetmedica, Inc. The authors thank the personnel who provided animal care and husbandry.

Conflict of interest

Dr Fangman was employed by Boehringer Ingelheim Vetmedica, Inc, during this study.

References

1. Weimer SL, Johnson AK, Fangman TJ, Karriker LA, Tyler HD, Stalder KJ. Comparison of nursery pig behavior assessed using human observation and digital-image evaluation methodologies. *J Swine Health Prod.* 2014;22:116–124.
2. European Commission. 2009. Welfare Quality Assessment Protocol for Pigs. Available at <http://edepot.wur.nl/233470>. Accessed 12 October 2017.
- *3. National Pork Board. *Pork Quality Assurance Plus Handbook.* 2016; version 3. <https://d3fn-s0a45gcg1a.cloudfront.net/sites/all/files/documents/PQAPlus/V3.0/BinderMaterial/Tab%202/1%20PQAHandbook.pdf>. Accessed 18 October 2017.
4. Johnson AK, Kline JK, Witte R, Holt W, Stalder KJ, Layman LL, Karriker LA, de Rodas B. Differences in nursery pigs' behavior on the day of vaccination. *Animal Industry Report* 2011;R2639.

Table 5: Commercial nursery pig snout and tail-base pen mean proximities (cm) from the index finger of a human observer during a human approach paradigm (HAP) within the behavior categories Touched, Oriented, and Not Oriented*

No. of pens	Injection treatment			P
	Vaccine A 48	Vaccine B 51	VSAL 50	
Pre-injection				
Touched, snout††	14.2 ± 2.5	14.3 ± 2.4	15.6 ± 2.3	.88
Touched, tail base	74.2 ± 2.2	73.9 ± 2.0	76.8 ± 2.2	.57
Oriented, snout	85.8 ± 2.3	86.9 ± 2.3	83.9 ± 2.3	.63
Oriented, tail base	116.4 ± 2.0	115.8 ± 2.0	114.5 ± 2.0	.80
Not Oriented, snout	119.8 ± 2.3	113.1 ± 2.4	116.4 ± 2.2	.13
Not Oriented, tail base	127.5 ± 1.5	125.7 ± 1.5	128.5 ± 1.4	.37
Post injection				
Touched, snout	28.8 ± 4.6	23.6 ± 6.4	18.2 ± 4.5	.26
Touched, tail base	70.5 ± 2.4	75.7 ± 3.4	72.3 ± 2.1	.44
Oriented, snout	83.8 ± 2.3 ^b	91.8 ± 2.2 ^a	87.7 ± 2.1 ^{ab}	< .05
Oriented, tail base	110.9 ± 2.3 ^b	121.1 ± 2.4 ^a	118.4 ± 2.2 ^a	< .01
Not Oriented, snout	121.5 ± 2.1	124.3 ± 2.0	124.8 ± 2.2	.49
Not Oriented, tail base	128.7 ± 1.3	127.0 ± 1.4	131.6 ± 1.4	< .10

* Vaccines and schedules described in Table 1.

† Ethogram of behaviors and postures described in Table 2.

‡ Snout anatomical measure was defined as the midpoint of the superior nose, and tail base was defined as the point of the pig's superior rear located at the tail base. Snout and tail-base proximities were measured using the ruler tool in Adobe Photoshop CS5 (Adobe Systems Inc, San Jose, California). In order to determine the actual distance in cm for snout distance, lengths collected from the digital image using the Adobe ruler were converted using the length of the nursery feeder (90.4 cm) and the feeder radius in pixels (620 pixels) for the digital image using the Adobe ruler tool. The conversion ratio was 6.9 (620 pixels ÷ 90.4 cm = 6.9).

^{ab} Means within a row with no common superscript are significantly different (LS Means; $P < .05$).

5. National Research Council. *Nutrient Requirements of Swine*. 10th ed. Washington, DC: National Academy Press; 1995.

6. Hemsworth PH, Barnett JL. The effect of aver- sively handling pigs, either individually or in groups, on their behaviour, growth and corticosteroids. *Appl Anim Behav Sci*. 1991;30:61–72.

7. Tanida H, Miura A, Tanaka T, Yoshimoto T. Behavioural response to humans in individu- ally handled weanling pigs. *App Anim Behav Sci*. 1995;42:249–259.

8. Harding JC. The clinical expression and emer- gence of porcine circovirus 2. *Vet Microbiol*. 2004;98:131–135.

*9. Boehringer Ingelheim Vetmedica, Inc. Ingelvac CircoFLEX[®]. A PCV2 vaccine that pampers pigs and pork. Technical Bulletin. 2006.

10. Fangman TJ, Johnson AK, Okones J, Edler RA. Willingness to approach behavior of weaned pigs following injection with *Mycoplasma hyopneumoniae*. *J Swine Health Prod*. 2011;19:19–25.

11. Fangman T, Edler R, Baumert D, Dubois P. Willingness to approach behavior and feed disap- pearance of weaned pigs following vaccination with *Mycoplasma vaccines*. *Appl Anim Welf Sci*. 2009;12:149–150.

*12. Bretey B, Edler R, Diaz E. An innovative method for quantifying animal behavior response to various immunization protocols. *Proc AASV*. Dallas, Texas. 2009; 295–296.

*13. Miyashita M, Yamaguchi T, Shimomura Y. Behaviour in weaned piglets following vaccination with different PCV2 vaccines. *International Pig Topics*. 2010;25:19.

14. Hart BL. Beyond fever: comparative perspec- tives on sickness behaviour. In: Breed M, Moore J, eds. *Encyclopedia of Animal Behavior*, 1st ed. Oxford, UK: Academic Press; 2010; 205–210.

15. Millman ST. Sickness behavior and its relevance to animal welfare assessment at the group level. *Anim Welf*. 2007;16:123–125.

16. Rushen J, Taylor AA, de Passillé AM. Domestic animals' fear of humans and its effect on their wel- fare. *Appl Anim Behav Sci*. 1995;65:285–303.

17. Hemsworth PH, Barnett JL, Campbell RG. A study of the relative averseness of a new daily injection procedure for pigs. *Appl Anim Welf Sci*. 1996;49:389–401.

18. Andersen IL, Knut EB, Førvik G, Janczak AM, Bakken M. Behavioural evaluation of methods for assessing fear responses in weaned pigs. *Appl Anim Behav Sci*. 2000;69:227–240.

19. Scott K, Laws DM, Courboulay V, Meunier- Salaün MC, Edwards S. Comparison of methods to assess fear of humans in sows. *Appl Anim Behav Sci*. 2009;118:36–41.

* Non-refereed references.



Serum and mammary secretion antibody responses in porcine epidemic diarrhea-immune gilts following porcine epidemic diarrhea vaccination

Jordan Bjustrom-Kraft, BS; Katie Woodard, DVM; Luis Giménez-Lirola, PhD; Blake Setness, BS; Ju Ji, MS; Pete Lasley, MS, DVM; Eric Nelson, MA, PhD; Jianqiang Zhang, MD, PhD; David Baum, DVM, PhD; Phillip Gauger, DVM, PhD; Rodger Main, DVM, PhD; Jeff Zimmerman, DVM, PhD

Summary

Objective: In the sow herd, maintaining levels of immunity sufficient to protect neonatal pigs is an important aspect in porcine epidemic diarrhea virus (PEDV) control. This study compared anamnestic responses to two commercially available PEDV vaccines.

Materials and methods: PEDV antibody-positive gilts ($n = 36$) in a commercial production system were each randomly (www.random.org) assigned to one of five vaccination protocols: no vaccine (controls); PEDV vaccine A (2 weeks pre-farrow); PEDV vaccine A (5 and 2 weeks pre-farrow); PEDV vaccine B (2 weeks

pre-farrow); and PEDV vaccine B (5 and 2 weeks pre-farrow). Serum, colostrum, and milk samples collected over the course of the study were tested for PEDV IgG, IgA, and neutralizing antibody (NAb).

Results: Analysis of the data from 32 animals completing the study found that vaccine induced a clear anamnestic response, ie, vaccinates had higher antibody concentrations than controls for most tests and specimens, but no difference was detected between one versus two doses of vaccine, and few differences in response were detected for vaccine A versus B. A positive but weak correlation was detected between IgG in serum and IgA in colostrum ($P = .012$; $r = .44$).

Implications: Under the conditions of this study, PEDV-vaccinated gilts have higher IgG, IgA, and NAb responses than nonvaccinated controls in all diagnostic specimens tested. In breeding herds, direct measurement of PEDV IgA or NAb in colostrum and milk will provide a more accurate measurement of lactogenic immunity than serological testing.

Keywords: swine, PEDV, vaccination, antibody

Received: February 20, 2017

Accepted: June 29, 2017

Resumen - Respuesta de anticuerpos en suero y secreción mamaria en primerizas inmunes a la diarrea epidémica porcina después de la vacunación contra diarrea epidémica porcina

Objetivo: En las piara de hembras, mantener los niveles de inmunidad suficientes para proteger a los lechones neonatos, es un aspecto importante en el control del virus de la diarrea epidémica porcina (PEDV por sus siglas en inglés). Este estudio comparó la

respuesta anamnésica de dos vacunas comerciales disponibles de PEDV.

Materiales y métodos: En un sistema de producción comercial, se asignaron aleatoriamente (www.random.org) primerizas positivas ($n = 36$) a anticuerpos contra PEDV, a uno de cinco protocolos de vacunación: sin vacuna (controles); PEDV vacuna A (2 semanas pre-parto); PEDV vacuna A (5 y 2 semanas pre-parto); PEDV vacuna B (2 semanas pre-parto); y PEDV vacuna B

(5 y 2 semanas pre-parto). Se analizaron muestras de suero, calostro, y leche recolectadas en el curso del estudio en busca de IgG, IgA contra PEDV, y anticuerpos neutralizantes (NAb por sus siglas en inglés).

Resultados: El análisis de datos de 32 animales que completaron el estudio mostró que la vacuna indujo una respuesta anamnésica clara, esto es: las primerizas vacunadas tuvieron concentraciones de anticuerpos más altos que las controles en la mayoría de las pruebas y especímenes, pero no se detectó diferencia entre una y dos dosis de vacuna, y se detectaron pocas diferencias entre la respuesta a la vacuna A y la B. Se detectó una correlación positiva débil entre IgG en suero e IgA en calostro ($P = .012$; $r = .44$).

Implicaciones: Bajo las condiciones de este estudio, en todos los especímenes de diagnóstico analizados, las primerizas vacunadas contra el PEDV tienen mayor respuesta a IgG, IgA, y NAb que las hembras control no vacunadas. En hatos de cría, la medida directa de IgA o NAb en calostro y leche contra PEDV proporcionará una medida más exacta de la inmunidad lactogénica que la prueba serológica.

JBK, KW, LGL, BS, JZ, DB, PG, RM, JZ: Department of Veterinary Diagnostic and Production Animal Medicine, College of Veterinary Medicine, Iowa State University, Ames, Iowa.

JJ: Department of Statistics, College of Liberal Arts and Sciences, Iowa State University, Ames, Iowa.

PL: Smithfield Hog Production Missouri, Princeton, Missouri.

EN: South Dakota Animal Disease Research and Diagnostic Laboratory, South Dakota State University, Brookings, South Dakota.

Corresponding author: Dr Jeffrey Zimmerman, Veterinary Diagnostic Laboratory College of Veterinary Medicine, Iowa State University, 1850 Christensen Drive, Ames, IA 50011-1134; Tel: 515-294-1073; Fax: 515-294-3564; jjzimm@iastate.edu.

This article is available online at <http://www.aasv.org/shap.html>.

Bjustrom-Kraft J, Woodard K, Giménez-Lirola L, et al. Serum and mammary secretion antibody responses in porcine epidemic diarrhea-immune gilts following porcine epidemic diarrhea vaccination. *J Swine Health Prod.* 2018;26(1):34–40.

Résumé - Production d'anticorps sériques et dans les sécrétions mammaires chez des cochettes immunes à la diarrhée épidémique porcine suite à la vaccination contre la diarrhée épidémique porcine

Objectif: Dans un troupeau de truies, le maintien d'un degré d'immunité suffisant pour protéger les porcelets nouveau-nés est un aspect important dans la lutte contre le virus de la diarrhée épidémique porcine (VDEP). Cette étude a comparé les réponses anamnestiques à deux vaccins contre le VDEP disponibles commercialement.

Matériels et méthodes: Des cochettes ayant des anticorps contre le VDEP (n = 36) dans un système commercial de production ont chacune été assignées au hasard (www.random.org) à l'un des cinq protocoles de

vaccination: aucun vaccin (témoins); vaccin VDEP A (2 semaines pré-mise-bas); vaccin VDEP A (5 et 2 semaines pré-mise-bas); vaccin VDEP B (2 semaines pré-mise-bas); et vaccin VDEP B (5 et 2 semaines pré-mise-bas). Des échantillons de sérum, de colostrum, et de lait prélevés durant la durée de l'étude ont été testés pour la présence d'IgG, d'IgA, et d'anticorps neutralisants (AcN) contre le VDEP.

Résultats: L'analyse des données provenant des 32 animaux complétant l'étude a démontré que le vaccin induisait une réponse anamnestique claire, ie, les animaux vaccinés avaient des concentrations d'anticorps plus élevées que les témoins pour la majorité des tests et des spécimens, mais aucune dif-

férence ne fut détectée entre l'administration d'une versus deux doses de vaccin, et peu de différences furent détectées dans la réponse au vaccin A versus le vaccin B. Une corrélation positive mais faible a été détectée entre les IgG sériques et les IgA dans le colostrum ($P = 0,012$; $r = 0,44$).

Implications: Dans les conditions de la présente étude, des cochettes vaccinées contre le VDEP avaient des concentrations plus élevées d'IgG, d'IgA, et d'AcN que les témoins non-vaccinés dans tous les échantillons testés. Dans les troupeaux reproducteurs, la mesure directe d'IgA ou d'AcN contre le VDEP dans le colostrum et le lait fournira une mesure plus précise de l'immunité lactogène que des tests sérologiques.

Porcine epidemic diarrhea virus (PEDV) is an enveloped, single-stranded, positive-sense RNA virus belonging to the family *Coronaviridae*.¹ In susceptible herds, PEDV infections are most notably characterized by the rapid onset of severe watery diarrhea and vomiting in pigs of all ages, with morbidity and mortality approaching 100% in suckling piglets.¹ Outbreaks of diarrhea were first described in Europe in the early 1970s, with the virus finally identified in 1978.² By the mid-1980s, outbreaks were rarely reported in Europe and were most often associated with weaned pigs.¹ In Asia, PEDV was reported as the causative agent of an acute diarrheal disease outbreak in 1982. Distinct from Europe, PEDV outbreaks have been more clinically severe and significantly affecting swine health in Asia.¹ Although the western hemisphere was previously free of the infection, PEDV was detected in the United States (Ohio) in April 2013, with outbreaks subsequently reported throughout the United States.³ Since its initial introduction into the Americas, PEDV has been reported in Mexico, Canada, parts of the Caribbean, and Central and South America.⁴

Porcine epidemic diarrhea virus replicates in the cytoplasm of villus epithelial cells throughout the small intestine, causing degeneration of enterocytes and leading to villus atrophy and a reduction of the villus height: crypt depth ratio. Clinically, this results in diarrhea, vomiting, and dehydration.^{1,5} In endemically infected herds, management practices to protect neonatal piglets against porcine epidemic diarrhea (PED) commonly include sanitation and disinfection to reduce the viral load in the environment and efforts to stimulate lactogenic

immunity through intentional exposure of sows and gilts to PEDV and (or) vaccinating breeding stock prior to farrowing with commercially available (killed or non-replicating) PEDV vaccines. Neonatal piglets are particularly susceptible to the effects of PEDV infection, but PEDV-immune sows are able to help protect their piglets by providing "lactogenic" immunity. That is, piglets can be protected from the effects of PEDV infection by the consumption of anti-PEDV antibodies in colostrum and milk from sows previously infected with PEDV. In particular, IgG in colostrum has been shown to improve the survivability of PEDV-infected piglets, and secretory IgA (sIgA) protects against enteric disease.^{6,7}

A key concept is that the development of effective maternal immunity against PEDV and other coronaviruses requires "productive" enteric infection. That is, enteric viral replication must be sufficient to stimulate the development of IgA plasmablasts that then traffic to the mammary glands where they produce sIgA for mammary secretions.⁶ Because current PEDV vaccines available in the United States are inactivated, they cannot stimulate protective levels of lactogenic immunity in PEDV-naïve animals. Nevertheless, parenteral PEDV vaccines may serve a valuable role in maintaining herd immunity by safely stimulating an anamnestic response in previously infected dams. To address this question, replacement gilts (n = 36) infected with PEDV at 13 weeks of age were each vaccinated at 5 and (or) 2 weeks pre-farrowing with one of two commercial PEDV vaccines. The response to each vaccine was evaluated by comparing antibody responses in serum and

mammary secretions collected over time post vaccination.

Materials and methods

This project was approved by the Iowa State University Office for Responsible Research.

Experimental design. Porcine epidemic diarrhea virus antibody-positive gilts (n = 36) in a commercial production system were each randomly assigned to one of five vaccination protocols. Colostrum, blood for serum, and fecal swab samples were collected within 12 hours post farrowing. Milk samples were collected at 3, 10, and 21 days post farrowing (DPF). Fecal swabs were tested by real-time reverse transcriptase polymerase chain reaction (rRT-PCR) to confirm the absence of PEDV shedding. Serum, colostrum, and milk samples were tested by PEDV whole virus (WV) IgG and IgA ELISAs and for neutralizing antibody (NAb) by PEDV fluorescent focus neutralization assay (FFN). Thirty-two gilts completed the study, ie, farrowed viable litters and provided a full complement of samples. Data were analyzed using a mixed-effect model to compare antibody responses in serum, colostrum, and milk.

Vaccines. Vaccine A was a conditionally licensed (June 2014), commercially manufactured (Harrisvaccines, Inc, Ames, Iowa) PEDV vaccine based on replicon particle (RP) technology. Replicon particles are RNA vectors that can express foreign antigens in vivo because they contain nonstructural genes, but cannot replicate in the animal because they lack structural genes. The PEDV vaccine used in this study was an alphavirus-derived replicon particle vaccine expressing

the PEDV spike gene, hence the vaccine was designed to stimulate an immune response against the PEDV spike glycoprotein. The vaccine was labeled for intramuscular (IM) use in healthy swine 3 weeks of age or older. Two 1-mL doses were recommended, with the second dose given approximately 3 weeks after the first.

Vaccine B was a conditionally licensed (September 2014), commercially manufactured (Zoetis, Inc, Florham Park, New Jersey), inactivated, adjuvanted PEDV vaccine derived from a virus strain isolated in the United States (USA/Colorado/2013). Vaccine B was labeled for IM use in healthy pregnant sows or gilts. Two 2-mL doses given 3 weeks apart were recommended, with the second dose given 2 weeks pre-farrowing. In previously vaccinated sows, one dose 2 weeks before farrowing was recommended.

Animals. Farm management intentionally exposed study animals to PEDV at 13 weeks of age (approximately 8 months prior to vaccination) by mixing PEDV-positive fecal material with water and spraying the feed and the pigs' oral-nasal area using a hand-held sprayer, as described elsewhere.⁸ At approximately 35 weeks of age, farm management selected animals for entry into a commercial breeding farm (Missouri). Prior to entry, individual serum and fecal swab samples were collected and tested to verify that each animal was PEDV serum-antibody-positive, but not shedding PEDV. Gilts were bred by artificial insemination beginning at approximately 40 weeks of age, and each was assigned to one of four breed groups by farm management on the basis of their projected farrowing date.

Vaccination protocols. A randomized block design was used in the study, with each of the five vaccination protocols (Table 1) allocated to each breed group (block): no vaccine (controls); one dose of vaccine A at 2 weeks pre-farrow; one dose of vaccine A at 5 weeks and a second dose at 2 weeks pre-farrow; one dose of vaccine B at 2 weeks pre-farrow; and one dose of vaccine B at 5 weeks and one dose at 2 weeks pre-farrow. Gilts within breed groups were each randomly assigned to a vaccination protocol using a random sequence generator (random.org).

Sample collection and processing. Blood for serum and fecal swab samples were collected from gilts at 5 weeks pre-farrow and within 12 hours post farrow. Serum samples were centrifuged at the laboratory, aliquoted,

and stored at -20°C. Fecal swab samples were collected using a commercial collection and transport system (StarswabII; Starplex Scientific Inc, Cleveland, Tennessee) and stored at -20°C. Prior to testing, swabs were suspended in 1 mL of phosphate buffered saline (PBS) (1X pH 7.4; Invitrogen Corporation, Carlsbad, California), and vortexed, and the liquid was submitted for testing by PEDV rRT-PCR.

Mammary secretions were collected within 12 hours of farrowing and 3, 10, and 21 days post farrow. Prior to collection, 1 mL of oxytocin (Bimeda-MTC Animal Health Inc, Cambridge, Ontario, Canada) was injected in the perivulvar region to stimulate colostrum and milk letdown. At the laboratory, samples were aliquoted and stored at -20°C. Prior to antibody testing, mammary secretions (colostrum and [or] milk) were processed by centrifugation at 13,000g for 15 minutes at 4°C to remove fat and debris. Thereafter, Rennet (*Mucor miebei*, Sigma R5876) was added (5 µL of stock solution per mL of mammary secretion) to coagulate the defatted samples. After incubation at 37°C for 30 minutes, samples were centrifuged for 15 minutes at 2000g and the supernatant was collected for antibody testing.

Porcine epidemic diarrhea virus RNA extraction and real-time reverse transcriptase PCR (rRT-PCR). In brief, 90 µL of viral RNA was eluted from rectal swabs, fecal samples, or oral-fluid specimens using the Ambion MagMAX viral RNA isolation kit (Life Technologies, Carlsbad, California) and a KingFisher 96 magnetic particle processor (Thermo-Fisher Scientific, Waltham, Massachusetts) following the procedures provided by the manufacturers. Samples were tested for PEDV using a PEDV N gene-based rRT-PCR described in Madson et al⁹ and performed routinely at the Iowa State University Veterinary Diagnostic Laboratory (ISU-VDL SOP 9.5263). The forward primer sequence was 5'-CGCAAAGACTGAACCCAC-TAACCT-3', the reverse primer sequence was 5'-TTGCCTCTGTTGTTACTTG-GAGAT-3', and the probe sequence was 5'-FAM-TGTTGCCAT/ZEN/TACCAC-GACTCCTGC-Iowa Black-3'. The eluted RNA, primers, and probe were mixed with commercial reagents (TaqMan Fast Virus 1-Step Master Mix; Life Technologies) and the rRT-PCR reactions were conducted on an ABI 7500 Fast instrument (Life Technologies) in fast mode as follows: one cycle

at 50°C for 5 minutes, one cycle at 95°C for 20 seconds, 40 cycles at 95°C for 3 seconds, and 60°C for 30 seconds. The results were analyzed using an automatic baseline setting with a threshold at 0.1. Quantification cycle (Cq) values < 35 were considered positive for PEDV.

PEDV whole virus (WV) antibody ELISA.

The PEDV WV ELISA has been fully described.⁸ In brief, US prototype PEDV isolate (USA/NC35140/2013)¹⁰ was propagated on Vero cells (ATCC CCL-81) at 37°C in a 5% CO₂ incubator. After 3 to 4 days of incubation, flasks were subjected to one freeze-thaw cycle, the contents were harvested, and cell debris was removed by centrifugation at 4000g for 15 minutes. Thereafter, the virus was pelleted by ultracentrifugation at 140,992g for 3 hours and processed to produce a purified viral antigen solution. The purified virus was re-suspended in 100 µL PBS (1X pH 7.4) at a 1:100 dilution of the original supernatant volume and stored at -80°C. Polystyrene 96-well microtitration plates (Nalge Nunc, Rochester, New York) were then manually coated (100 µL per well) with the viral antigen solution, incubated at 4°C overnight, washed five times with PBST (1X pH 7.4 + 0.1% Tween-20), and then blocked with 300 µL per well of a solution containing 1% bovine serum albumin (Jackson ImmunoResearch Inc, West Grove, Pennsylvania). The performance of each lot of plates was standardized using a panel of PEDV serum antibody-negatives and positives. Plate lots with a coefficient of variation ≥ 10% were rejected.

Enzyme-linked immunosorbent assay (ELISA) conditions for the detection of anti-PEDV IgA and IgG antibodies in serum and colostrum or milk (defatted) samples, including coating and blocking conditions, reagent concentrations, incubation times, and buffers, were identical, with the exception that goat anti-pig IgG (Fc) (1:20,000 for serum and colostrum or milk) or IgA (1:3000 dilution for serum and 1:50,000 dilution for colostrum and milk) horseradish peroxidase (HRP)-conjugated secondary antibody was used for the antibody isotype-specific ELISAs. Serum, colostrum, and milk samples were diluted 1:50, after which plates were loaded with 100 µL of the diluted sample per well. Plates were incubated at 25°C for 1 hour and then washed five times with PBST. Positive and negative plate controls, ie, antibody-positive and -negative experimental serum samples, were run in

duplicate on each ELISA plate. Thereafter, 100 μ L of peroxidase-conjugated goat anti-pig IgG (Fc) antibody (Bethyl Laboratories Inc, Montgomery, Texas) was added to each well and the plates were incubated at 25°C for 1 hour. After a washing step, the reaction was visualized by adding 100 μ L of tetramethylbenzidine-hydrogen peroxide (Dako North America, Inc, Carpinteria, California) substrate solution to each well. After a 5-minute incubation at room temperature, the reaction was stopped by the addition of 50 μ L of stop solution (1 M sulfuric acid) to each well. Reactions were measured as optical density (OD) at 450 nm using an ELISA plate reader (Biotek Instruments Inc, Winooski, Vermont) operated with commercial software (GEN5, Biotek Instruments Inc). The antibody response in serum, colostrum, and milk samples was expressed as sample-to-positive (S:P) ratio calculated as $S:P \text{ ratio} = (\text{sample OD} - \text{negative control mean OD}) \div (\text{positive control mean OD} - \text{negative control mean OD})$.

Fluorescent focus neutralization assay (FFN). The FFN was performed at the South Dakota Animal Disease Research and Diagnostic Laboratory using a protocol described by Okda et al.¹¹ In brief, test and control serum samples or rennet-treated milk and colostrum samples were heat inactivated at 56°C for 30 minutes, then serially diluted in serum-free modified Eagles medium (MEM) containing 1.5 μ g per mL L-1-Tosylamide-2-phenylethyl chloromethyl ketone (TPCK)-treated trypsin in 96-well plates to achieve a final volume of 100 μ L per well. Next, 100 μ L of PEDV stock diluted to a concentration of 100 to 200 fluorescent focus units (FFU) per 100 μ L was added to each well and plates were incubated at 37°C for 1 hour. Plates containing confluent 3-day-old monolayers of Vero-76 cells (ATCC CRL-1587) were washed three times with serum-free MEM prior to transfer of the serum-virus mixtures to corresponding wells of these plates. After 1 hour incubation at 37°C, the serum-virus mixture was removed, monolayers were washed once with serum-free MEM, and 150 μ L per well replacement media (MEM with 1.5 μ g per mL TPCK-treated trypsin) was added to each well. Plates were incubated 24 hours at 37°C, then monolayers were fixed for 15 minutes with 80% acetone in water, dried, and stained with fluorescein-conjugated PEDV anti-nucleocapsid (N) protein monoclonal antibody SD6-29. Titers were reported as the reciprocal of the greatest sample dilution resulting in a 90% or greater reduction in FFU relative

Table 1: Experimental design showing the number of gilts assigned to each PEDV vaccination protocol*

Trt	Vaccination protocol	No. of gilts
1	Non-vaccinated (controls)	4
2	1 mL IM; 2 weeks pre-farrow	6
3	1 mL IM; 5 and 2 weeks pre-farrow	8
4	2 mL IM; 2 weeks pre-farrow	7
5	2 mL IM; 5 and 2 weeks pre-farrow	7

* Treatment groups 2 and 3 vaccinated with Vaccine A; Harrisvaccines, Inc, Ames, Iowa. Treatment groups 4 and 5 vaccinated with Vaccine B; Zoetis, Inc, Florham Park, New Jersey. PEDV = porcine epidemic diarrhea virus; Trt = treatment.

to virus control well. An FFN titer < 20 was considered negative.

Data analysis. Statistical analyses were performed using commercial statistical software (SAS Version 9.4; SAS Institute, Inc, Cary, North Carolina) using test results on serum (n = 64), colostrum (n = 32), and milk samples (n = 96). A nonparametric one-way analysis of variance (ANOVA) was used to test for differences among treatment groups for IgG, IgA, and NAb by sample type (serum, colostrum, or milk). A general linear model (Proc GLIMMIX) was used to make pairwise comparisons in antibody responses between treatment groups by sample type. Correlation (Proc CORR) was used to test the association between antibody responses (IgG, IgA, and NAb) in serum (collected at farrowing) and antibody responses in colostrum or milk (3 DPF). Antibody responses in milk were evaluated by repeated measures analysis (Proc GLIMMIX) using a compound symmetry covariance structure. Gilt ID, sample type, and treatment were used as categorical variables. Milk was used as a time factor and the response was the test result (IgG, IgA, NAb). Treatments (Control, Vaccine A, Vaccine B) and sample type were explanatory variables.

Results

All fecal swab samples (n = 64) collected from gilts at 5 weeks pre-farrow and within 12 hours post farrow were PEDV rRT-PCR-negative. Statistical analysis of serum antibody responses (IgG, IgA, NAb) at 5 weeks pre-farrow, ie, prior to vaccination, found no difference ($P > .05$) in the antibody test results among the five treatment groups. Within vaccine treatment groups (A, B), comparison of test responses by specimen and

time of collection found no difference between one dose versus two doses. Therefore, the data were collapsed and analyzed on the basis of three treatment groups: nonvaccinated control, Vaccine A, and Vaccine B. Results and statistically significant differences among the three treatment groups are given in Table 2 by specimen (serum, colostrum, milk) and test (IgG, IgA, NAb).

Compared to nonvaccinated controls, gilts administered Vaccine A showed higher IgG in serum at farrowing ($P = .001$) and in colostrum ($P = .01$); higher IgA in colostrum ($P = .01$); and higher neutralizing antibody in serum at farrowing ($P = .02$), in colostrum ($P = .0001$), and in milk samples collected at 3 and 21 DPF ($P < .05$).

Compared to nonvaccinated controls, gilts administered Vaccine B showed higher IgG in serum at farrowing ($P = .0001$), in colostrum ($P = .0001$), and in milk collected at 3 and 21 DPF ($P < .04$); higher IgA in serum at farrowing ($P = .01$) and in colostrum ($P \leq .02$); and higher neutralizing antibody in colostrum ($P < .0001$).

A comparison of antibody responses among vaccinates showed that gilts receiving Vaccine B had higher IgG responses in serum collected at farrowing ($P = .0001$) and in colostrum ($P = .01$) compared to gilts receiving Vaccine A. No other significant differences were detected between the two vaccine groups.

In vaccinated animals (Vaccine A and Vaccine B), IgG, IgA, and NAb in milk declined ($P \leq .01$) between 3 and 10 DPF, but not from 10 to 21 DPF. In nonvaccinated controls, no significant decline was detected in IgG, IgA, or NAb responses.

Table 2: Serum and mammary secretion antibody responses* (least squares means) in PEDV-immune gilts following PEDV vaccination†

Specimen (time of collection)	Test	Control (95% CI)	Vaccine A (95% CI)	Vaccine B (95% CI)
Serum (5 weeks pre-farrow)	IgG (S:P)	1.61(0.49, 2.73)	1.68 (1.27, 2.08)	1.72 (1.29, 2.16)
	IgA (S:P)	1.08 (-0.37, 2.54)	1.61 (0.84, 2.39)	1.61 (0.99, 2.22)
	FFN (titer)	17 (6, 48)	57 (26, 121)	59 (28, 126)
Serum (≤ 24 hours post farrow)	IgG (S:P)	1.01 (-0.07, 2.10)	2.03‡ (1.72, 2.33)	2.81‡§ (2.64, 2.99)
	IgA (S:P)	2.30 (-1.36, 5.95)	3.83 (3.09, 4.58)	4.27‡ (3.56, 4.97)
	FFN (titer)	135 (1, 12607)	950 (502, 1810)	610 (329, 1130)
Colostrum (≤ 24 hours post farrow)	IgG (S:P)	1.31 (0.28, 2.34)	2.43‡ (2.03, 2.83)	2.98‡§ (2.76, 3.20)
	IgA (S:P)	0.63 (0.26, 1.00)	1.18‡ (0.97, 1.39)	1.32‡ (1.12, 1.53)
	FFN (titer)	160 (21, 1198)	3121‡ (1927, 5053)	2207‡ (1494, 3261)
Milk (3 days post farrow)	IgG (S:P)	0.18 (-0.06, 0.42)	0.83 (0.46, 1.21)	0.98‡ (0.55, 1.40)
	IgA (S:P)	0.46 (0.07, 0.85)	0.87 (0.65, 1.09)	0.85 (0.62, 1.08)
	FFN (titer)	160 (65, 394)	1344‡ (601, 3023)	610 (260, 1430)
Milk (10 days post farrow)	IgG (S:P)	0.08 (-0.06, 0.23)	0.21 (0.03, 0.39)	0.31 (0.17, 0.44)
	IgA (S:P)	0.52 (-0.04, 1.07)	0.71 (0.51, 0.91)	0.74 (0.50, 0.98)
	FFN (titer)	80 (3, 2051)	277 (141, 538)	226 (93, 549)
Milk (21 days post farrow)	IgG (S:P)	0.03 (-0.02, 0.08)	0.15 (0.06, 0.23)	0.19‡ (0.11, 0.26)
	IgA (S:P)	0.46 (0.02, 0.90)	0.72 (0.49, 0.94)	0.72 (0.48, 0.97)
	FFN (titer)	57 (4, 782)	320‡ (128, 799)	196 (87, 437)

* PEDV Whole Virus IgG ELISA; PEDV Whole Virus IgA ELISA; PEDV fluorescent focus neutralization (FFN) assay.

† Vaccine A: Harrisvaccines 1 and 2 doses; Vaccine B: Zoetis 1 and 2 doses. Within vaccine treatment groups (A, B), comparison of test responses by specimen and time of collection found no difference in one dose versus two doses. Therefore, the data were collapsed and analyzed as nonvaccinated control (n = 4), Vaccine A (n = 14), and Vaccine B (n = 14).

‡ Significantly different from nonvaccinated control group ($P < .05$; Kruskal-Wallis Test).

§ Significantly different from Vaccine A ($P < .05$; linear model).

Among all groups (n = 32 gilts) and regardless of treatment, a positive correlation was detected between IgG antibody responses in serum collected at farrowing and IgG in colostrum ($P < .0001$; $r = .73$) and likewise, between IgG in serum collected at farrowing and IgG in milk collected at 3 DPF ($P = .01$; $r = .47$). No correlation was detected between IgA or NAb in serum collected at farrowing and colostrum, nor between serum and milk collected at 3 DPF. In contrast, a positive correlation was detected between IgG in serum and IgA in colostrum ($P = .01$; $r = .44$), but not between IgG in serum and IgA in milk collected at 3, 10, and 21 DPF.

Discussion

Our expectations for PEDV lactogenic immunity are primarily modeled on transmissible gastroenteritis virus (TGEV) research. In TGEV, it is known that an effective lactogenic response requires an episode of enteric

viral replication sufficient to stimulate the development of TGEV-specific IgA plasmablasts. These plasmablasts then migrate to the mammary glands where they reside and produce the TGEV-specific sIgA present in mammary secretions.⁶ Secretory IgA (sIgA) antibodies in milk neutralize TGEV in the intestinal lumen and protect suckling piglets from clinical disease.^{1,12} In the same fashion, it is assumed that PEDV-specific sIgA protects piglets by neutralizing virus in the gut and (or) blocking viral attachment to enterocytes. For PEDV, it has also been shown that systemic antibodies, such as those received by the piglet in colostrum, are also involved in protection. Specifically, Poonsuk et al⁷ showed that neonatal piglets with passive circulating PEDV antibody returned to normal body temperature faster and experienced less mortality, ie, fewer deaths after PEDV inoculation compared to controls, although circulating anti-PEDV antibody

did not improve piglet growth rates or reduce PEDV fecal shedding. Thus, PEDV lactogenic immunity includes PEDV-specific antibodies in both colostrum and milk.

Since its appearance in North America in April 2013, control of PEDV on commercial swine farms has been based on biosecurity, monitoring, and disease prevention. The prevention of clinical PED has been largely based on a combination of strict sanitation to reduce viral exposure to neonates and stimulation of lactogenic immunity through intentional exposure of sows to PEDV.⁶ Ideally, lactogenic immunity could be established in PEDV-naive animals through the use of vaccination, rather than exposure to live PEDV. However, it has been shown that highly-attenuated, live-virus oral TGEV vaccines replicate poorly in the gut and induce low milk sIgA antibody titers.¹ Presumably, modified-live PEDV vaccines may likely face the same

hurdle,⁶ and no licensed modified-live PEDV vaccines are currently available for use in the United States. Nevertheless, there is a clear need to optimize the level of PEDV immunity in sow herds with the tools at hand. Therefore, the aim of this study was to characterize the anamnestic antibody response of pregnant gilts (n = 32) inoculated with live PEDV approximately 8 months earlier to two commercially available PEDV vaccines (non-replicating or killed) administered 5 and (or) 2 weeks pre-farrow. All antibody responses (IgG, IgA, NAb) in serum, colostrum, and milk samples collected at farrowing and (or) post farrowing were numerically higher in vaccinated animals than in nonvaccinated control animals. Numerical differences in vaccinates versus controls were not necessarily significantly different, but this could be attributed to the relatively small numbers of animals in the study. To the knowledge of the authors, there are no refereed publications against which to compare these data, but the results suggest that one dose of either Vaccine A or Vaccine B administered 2 weeks prior to farrowing is sufficient to produce a meaningful increase in lactogenic immunity in previously exposed sows. This was not unexpected, because these gilts already had been infected and responded immunologically to PEDV.⁸

For the management of breeding-herd PEDV immunity and to guide decisions regarding the use of PEDV vaccines, it would be useful to be able to predict the expected level of PEDV antibody in colostrum and milk in pregnant animals prior to farrowing. Analysis of the data generated in this study found that serum IgG antibody responses were reasonably predictive of colostrum ($P < .0001$; $r = .73$) and day 3 milk ($P = .01$; $r = .47$) IgG antibody responses. These results are compatible with the fact that approximately 100% of IgG in colostrum comes from serum, whereas only approximately 30% of IgG in milk is derived from serum.¹³⁻¹⁶ In contrast, no correlation was detected between serum IgA or NAb responses and IgA or NAb levels in mammary secretions. This was not unexpected, given that only approximately 40% of IgA in colostrum and approximately 10% of IgA in milk is derived from the sow's serum.^{13,14} It is assumed that PEDV-specific sIgA plays a primary role in neutralizing virus in the gut and (or) blocking viral attachment to enterocytes. While paired PEDV serologic antibody testing of dams prior to and following vaccination may be useful for documenting individual sow responses to the

administration of a killed PEDV vaccine, direct measurement of PEDV IgA and (or) PEDV NAb in the colostrum and (or) milk will provide practitioners a more clinically relevant assessment of PEDV lactogenic immunity. In the current study, PEDV IgA was measured using the PEDV WV ELISA, and PEDV NAb was measured by PEDV FFN.

In conclusion, the tools currently available to swine producers and veterinarians for initiating and modulating PEDV humoral immune responses are exposure to live virus and boosting through vaccination with commercially available (non-replicating or killed) products. The findings of this study suggest vaccination of previously exposed gilts with the commercially available PEDV vaccines provides a measurable increase in the PEDV lactogenic immunity present in the dam's colostrum and milk. However, two key questions for "fine tuning" the use of PEDV vaccines in sow herds remain unanswered: what level of lactogenic antibody is needed to fully protect neonates against the clinical effects of PEDV, and how can we test to predict the level of lactogenic immunity that a sow will provide her piglets? Additional research is needed to address these questions for fully effective PEDV control in commercial sow herds.

Implications

- Exposure to infectious PEDV remains the primary tool for stimulating an effective immune response against PEDV.
- In previously infected animals, vaccination of gilts with commercial products can stimulate an anamnestic response. Thus, vaccination can be a useful tool for the management of PEDV in sow herds.
- Serum antibody does not predict maternal lactogenic (IgA) antibody levels in mammary secretions.
- Direct measurement of PEDV IgA and PEDV neutralizing antibody in colostrum or milk is a user-friendly and effective means for monitoring PEDV lactogenic immunity in breeding herds.

Acknowledgements

This study was funded in part by Checkoff Dollars administered through the National Pork Board, Des Moines, Iowa, and support from the Iowa State University Veterinary Diagnostic Laboratory.

Conflict of interest

None reported.

Disclaimer

Scientific manuscripts published in the *Journal of Swine Health and Production* are peer reviewed. However, information on medications, feed, and management techniques may be specific to the research or commercial situation presented in the manuscript. It is the responsibility of the reader to use information responsibly and in accordance with the rules and regulations governing research or the practice of veterinary medicine in their country or region.

References

1. Saif LJ, Pensaert MB, Sestak K, Yeo S, Jung K. Coronaviruses. In: Zimmerman JJ, Karriker LA, Ramirez A, Schwartz KJ, Stevenson GW, eds. *Diseases of Swine*. 10th ed. Ames, Iowa: Wiley and Sons; 2012:501-524.
2. Pensaert MB, de Bouck P. A new coronavirus-like particle associated with diarrhea in swine. *Arch Virol*. 1978;58:243-247.
3. Stevenson GW, Hoang H, Schwartz KJ, Burrough ER, Sun D, Madson D, Cooper VL, Pillatzki A, Gauger P, Schmitt BJ, Koster LG, Killian ML, Yoon KJ. Emergence of Porcine epidemic diarrhea virus in the United States: clinical signs, lesions, and viral genomic sequences. *J Vet Diagn Invest*. 2013;25:649-654.
- *4. ProMED-mail. Porcine Epidemic Diarrhea – Dominican Republic. ProMED-mail 2014; 12 Jul: 20140616.2544899. <http://www.promedmail.org/post/20140616.2544899>. Accessed 21 October 2017.
5. Madson DM, Arruda PHE, Magstadt DR, Burrough ER, Hoang H, Sun D, Bower LP, Bhandari M, Gauger P, Stevenson GW, Wilberts BL, Wang C, Zhang J, Yoon KJ. Characterization of porcine epidemic diarrhea virus isolate US/Iowa/18984/2013 infection in 1-day-old cesarean-derived colostrum-deprived piglets. *Vet Pathol*. 2015;53:44-52.
6. Chattha KS, Roth JA, Saif LJ. Strategies for design and application of enteric viral vaccines. *Annu Rev Anim Biosci*. 2015;3:375-395.
7. Poonsuk K, Giménez-Lirola LG, Zhang J, Arruda P, Chen Q, da Silva Carrion LC, Magtoto R, Pineyro P, Sarmento L, Wang C, Sun Y, Madson D, Johnson J, Yoon KJ, Zimmerman J, Main R. Does circulating antibody play a role in the protection of piglets against porcine epidemic diarrhea virus? *PLoS one*. 2016;11(4):p.e0153041.
8. Bjustrom-Kraft J, Woodard K, Giménez-Lirola L, Rotolo M, Wang C, Sun Y, Lasley P, Zhang J, Baum D, Gauger P, Main R, Zimmerman J. Porcine epidemic diarrhea virus (PEDV) detection and antibody response in commercial growing pigs. *BMC Vet Res* 2016;12:99. doi:10.1186/s12917-016-0725-5.
9. Madson DM, Magstadt DR, Arruda PHE, Hoang H, Sun D, Bower LP, Bhandari M, Burrough ER, Gauger PC, Pillatzki AE, Stevenson GW, Wilberts BL, Brodie J, Harmon KM, Wang C, Main RG, Zhang J, Yoon KJ. Pathogenesis of porcine epidemic diarrhea virus isolate (US/Iowa/18984/2013) in 3-week-old weaned pigs. *Vet Microbiol*. 2014;174:60-68.

CONVERSION TABLES

10. Chen Q, Gauger PC, Stafne MR, Thomas JT, Madson DM, Huang H, Zheng Y, Li G, Zhang J. Pathogenesis comparison between the United States porcine epidemic diarrhoea virus prototype and S-INDEL-variant strains in conventional neonatal piglets. *J Gen Virol.* 2016;97:1107–1121.

11. Okda F, Liu X, Singrey A, Clement T, Nelson J, Christopher-Hennings J, Nelson E, Lawson S. Development of an indirect ELISA, blocking ELISA, fluorescent microsphere immunoassay and fluorescent focus neutralization assay for serologic evaluation of exposure to North American strains of Porcine Epidemic Diarrhea Virus. *BMC Vet Res.* 2015;11:180.

12. Bohl EH, Gupta RK, Olquin MV, Saif LJ. Antibody responses in serum, colostrum, and milk of swine after infection or vaccination with transmissible gastroenteritis virus. *Infect Immun.* 1972;6:289–301.

13. Jensen AR, Elnif J, Burrin DG, Sangild PT. Development of intestinal immunoglobulin absorption and enzyme activities in neonatal pigs are diet dependent. *J Nutr.* 2001;131:3259–3265.

14. Geale PF. Characterization of porcine colostrum and its impact on piglet growth. PhD Dissertation, 2011. University of Sydney, Sydney Australia.

15. Stokes C, Bourne JF. Mucosal immunity. In: Halliwell REW, Gorman NT, eds. *Veterinary Clinical Immunology.* Philadelphia, Pennsylvania: WB Saunders Co; 1989:178–181.

16. Wagstrom EA, Yoon KJ, Zimmerman JJ. Immune components in porcine mammary secretions. *Viral Immunol.* 2000;13:383–397.

* Non-refereed reference.



Weights and measures conversions

Common (US)	Metric	To convert	Multiply by
1 oz	28.35 g	oz to g	28.4
1 lb (16 oz)	453.59 g	lb to kg	0.45
2.2 lb	1 kg	kg to lb	2.2
1 in	2.54 cm	in to cm	2.54
0.39 in	1 cm	cm to in	0.39
1 ft (12 in)	0.31 m	ft to m	0.3
3.28 ft	1 m	m to ft	3.28
1 mi	1.6 km	mi to km	1.6
0.62 mi	1 km	km to mi	0.62
1 in ²	6.45 cm ²	in ² to cm ²	6.45
0.16 in ²	1 cm ²	cm ² to in ²	0.16
1 ft ²	0.09 m ²	ft ² to m ²	0.09
10.76 ft ²	1 m ²	m ² to ft ²	10.8
1 ft ³	0.03 m ³	ft ³ to m ³	0.03
35.3 ft ³	1 m ³	m ³ to ft ³	35
1 gal (128 fl oz)	3.8 L	gal to L	3.8
0.264 gal	1 L	L to gal	0.26
1 qt (32 fl oz)	946.36 mL	qt to L	0.95
33.815 fl oz	1 L	L to qt	1.1

Temperature equivalents (approx)

°F	°C
32	0
50	10
60	15.5
61	16
65	18.3
70	21.1
75	23.8
80	26.6
82	28
85	29.4
90	32.2
102	38.8
103	39.4
104	40.0
105	40.5
106	41.1
212	100

$$^{\circ}\text{F} = (^{\circ}\text{C} \times 9/5) + 32$$

$$^{\circ}\text{C} = (^{\circ}\text{F} - 32) \times 5/9$$

Conversion chart, kg to lb (approx)

Pig size	Lb	Kg
Birth	3.3–4.4	1.5–2.0
Weaning	7.7	3.5
	11	5
	22	10
Nursery	33	15
	44	20
	55	25
	66	30
	99	45
Grower	110	50
	132	60
	198	90
	220	100
	231	105
Finisher	242	110
	253	115
	300	135
	661	300
	794	360
Sow	800	363
Boar		

1 tonne = 1000 kg

1 ppm = 0.0001% = 1 mg/kg = 1 g/tonne

1 ppm = 1 mg/L

Antibody evidence of porcine reproductive and respiratory syndrome virus detected in sera collected from feral swine (*Sus scrofa*) across the United States

Kerri Pedersen, MS; Ryan S. Miller, MS, PhD; Anthony R. Musante, MS; Timothy S. White, BS; James D. Freye II, BS; Thomas Gidlewski, MS, DVM

Summary

Feral swine sera from across the United States were tested for antibodies to porcine reproductive and respiratory syndrome virus. Antibodies to the virus were detected in 1.2% (68 of 5506) of the samples tested, suggesting that feral swine are unlikely to be an important source of spillback into domestic swine.

Keywords: swine, disease, feral swine, porcine reproductive and respiratory syndrome, *Sus scrofa*

Received: February 2, 2017

Accepted: June 13, 2017

Resumen - Evidencia de anticuerpos contra el virus del síndrome reproductivo y respiratorio porcino detectado en sueros de cerdos silvestres (*Sus scrofa*) a lo largo de los Estados Unidos

Se analizaron sueros de cerdos silvestres a lo largo de los Estados Unidos en busca de anticuerpos contra el virus del síndrome reproductivo y respiratorio porcino. Se detectaron anticuerpos contra el virus en 1.2% (68 de 5506) de las analizadas, lo que sugiere que es poco probable que los cerdos silvestre sean una fuente importante de fuga hacia la población porcina doméstica.

Résumé - Présence d'anticorps contre le virus du syndrome reproducteur et respiratoire porcine dans des échantillons de sérum prélevés de porcs sauvages (*Sus scrofa*) à travers les États-Unis

Des échantillons de sérum prélevés de porcs sauvages à travers les États-Unis ont été testés pour la présence d'anticorps contre le virus du syndrome reproducteur et respiratoire porcine. Des anticorps contre le virus ont été détectés dans 1,2% des échantillons testés (68 des 5506), suggérant ainsi que les porcs sauvages ne seraient pas une source importante de reflux du virus vers les porcs domestiques.

Feral swine (*Sus scrofa*) are an invasive and destructive species in the United States. Although originally introduced into the United States in the early 1500s by Spanish explorers,¹ their more recent range

expansion and rapidly increasing populations have led to concern not only because of the damage they cause to agricultural crops and ecosystems² through their rooting behavior, but also because of the numerous

pathogens they carry that are infectious to humans and livestock.³ While populations are concentrated in the southeastern part of the United States, the increasing geographic distribution of feral swine into northern regions of the country signifies a concurrent risk of the potential for increased pathogen transmission.⁴ Porcine reproductive and respiratory syndrome (PRRS) virus is of particular economic importance to the US commercial swine industry. The disease has been estimated to cost \$664 million annually or \$1.8 million per day in combined productivity losses to breeding and growing pig herds.⁵ First identified in the United States in 1987,⁶ PRRS is an important cause of late-term reproductive losses, severe pneumonia, reduced growth rates, and increased mortality.⁷ Although it may have been introduced from Europe by imported wild boar,⁸ the role of feral swine and wild boar in the transmission and maintenance of PRRS in the United States is uncertain. Previous small-scale surveys for PRRS, conducted in feral swine in Alabama, Arkansas, California, Florida, Georgia, Hawaii, Kansas, Louisiana, Michigan, Mississippi, Missouri, New

KP: United States Department of Agriculture, Animal and Plant Health Inspection Service, Wildlife Services, Fort Collins, Colorado.

RSM: United States Department of Agriculture, Animal and Plant Health Inspection Service, Veterinary Services, Fort Collins, Colorado.

ARM: United States Department of Agriculture, Animal and Plant Health Inspection Service, Wildlife Services, Concord, New Hampshire.

TSW: United States Department of Agriculture, Animal and Plant Health Inspection Service, Wildlife Services, St Paul, Minnesota.

JDF: United States Department of Agriculture, Animal and Plant Health Inspection Service, Wildlife Services, Madison, Tennessee.

TG: United States Department of Agriculture, Animal and Plant Health Inspection Service, Wildlife Services, National Wildlife Research Center, Fort Collins, Colorado.

Corresponding author: Kerri Pedersen, United States Department of Agriculture, Animal and Plant Health Inspection Service, Wildlife Services, 4101 LaPorte Avenue, Fort Collins, CO 80521; Tel: 970-266-6272; Fax: 970-266-6215; E-mail: Kerri.Pedersen@aphis.usda.gov.

This article is available online at <http://www.aasv.org/shap.html>.

Pedersen K, Miller RS, Musante AR, et al. Antibody evidence of porcine reproductive and respiratory syndrome virus detected in sera collected from feral swine (*Sus scrofa*) across the United States. *J Swine Health Prod.* 2018;26(1):41–44.

Mexico, North Carolina, Oklahoma, South Carolina, and Texas estimated the antibody prevalence as 1% to 3%^{2,9-12} However, there has been no national-level surveillance conducted for the disease in feral swine in the United States. Our objective was to fill this gap by establishing baseline antibody data for feral swine across the United States that could be used to identify areas of risk of pathogen transmission between domestic swine and feral swine.

Materials and methods

The United States Department of Agriculture, Animal and Plant Health Inspection Services' Wildlife Services removes feral swine for damage management purposes. Feral swine are lethally removed following the American Veterinary Medical Association Guidelines on Euthanasia. Damage is defined as destruction of agricultural crops, damage to urban areas, and impacts to native wildlife, in addition to transmission of pathogens to livestock, including domestic swine. Various pathogens have been documented in feral swine that can be transmitted to domestic swine.^{3,4} Sera collected from feral swine targeted for removal were tested for exposure to various pathogens, including PRRS virus (PRRSV). Samples were submitted to any one of eight accredited veterinary diagnostic laboratories in the United States for testing with an enzyme-linked immunosorbent assay (ELISA: PRRS X3 Antibody Test Kit; IDEXX Laboratories, Inc, Westbrook, Maine) according to the manufacturer instructions.

A hierarchical Bayesian model^{13,14} was used to estimate national- and state-level antibody prevalence in feral swine. Previous work has determined that PRRS antibody prevalence in feral swine varies regionally by the amount of domestic swine production.¹⁵ To account for this variation and to determine potential risks to domestic swine production, the antibody prevalence was estimated nationally for each state, and separately for states with large and small swine farms. Nationally, the median (50th percentile) number of domestic pig farms by state was 1200 farms. This number was used to distinguish states with large swine industries (≥ 1200 farms) from states with small swine industries (< 1200 farms). Samples collected in the same county were assumed to originate from the same feral swine population, and samples collected in the same month and year were considered a single sampling

event. The ELISA used for detection has an estimated sensitivity (SN) of 98.8% and specificity (SP) of 99.9%.¹⁶ Uncertainty regarding the test performance in feral swine and between the eight testing laboratories was accounted for by using beta distributed priors for SN ($\alpha = 35.55$, $\beta = 1.42$) and SP ($\alpha = 28.9$, $\beta = 1.03$) assuming 95% certainty that the ELISA SN and SP were greater than 90%. On the basis of previous studies,^{10,11} the prevalence was assumed to be below 10% with 95% certainty, and a moderately informative beta prior for prevalence ($\alpha = 1.45$, $\beta = 35.98$) was utilized. Posterior inference used 100,000 iterations from three Markov chain Monte Carlo (MCMC) simulations, with the first 20,000 iterations discarded as burn-in. Convergence was confirmed by using autocorrelation among samples and the Brooks-Gelman-Rubin convergence statistic.¹⁷ The highest posterior density (HPD) was used as an estimate of the expected national prevalence. Multivariate generalized linear model with a logit link, sometimes referred to as a fractional logit,¹⁸ was used to investigate the mean potential associations between state prevalence, the density of domestic swine production, and the size of domestic swine farms. The predicted HPD prevalence (response variable) for each contiguous state was regressed against National Agricultural Statistics Service (NASS) data reporting the total number of domestic swine farms, number of small farms (< 100 animals), number of large farms (≥ 2000 animals), and total inventory of swine. Differences in state prevalence were compared using the amount of posterior overlap and calculated the probability that the posterior distributions were different than the national prevalence. Bayesian models were fit using MCMC techniques and implemented in R (R Project for Statistical Computing, Vienna, Austria) and JAGS software (Just Another Gibbs Sampler, Vienna, Austria), and regression analysis was conducted in R.

Results

From October 1, 2013, through September 30, 2015, we submitted 5506 sera collected from feral swine in 316 counties of 26 states for PRRS antibody testing. At least one positive was detected in 43 counties of 14 states (Table 1), and the national antibody prevalence estimated by the Bayesian model was 1.9% (95% HPD interval = 0.3 to 7.2; Table 1). State level prevalence estimates varied from 0.8% (95% HPD interval = 0.09 to 4.1) in Kansas to 4.1% (95% HPD

interval = 0.8 to 9.5) in Michigan. Antibody prevalence in states with ≥ 1200 farms was 2.2% (95% HPD interval = 1.2 to 3.7) and was higher than in states with < 1200 farms (1.6%; 95% HPD interval = 1.0 to 2.4) with a moderate probability ($Pr = 0.51$) of being different. State antibody prevalence was positively associated with the total number of farms (log odds = 1.10; 95% confidence interval (CI) = 1.06-1.14; $P < .001$), but not associated with the number of domestic swine (log odds = 0.99; 95% CI = 0.98-1.0; $P \geq .05$). Farm size was a significant predictor of prevalence, with small farms being positively associated with prevalence (log odds = 1.11; 95% CI = 1.06-1.16; $P < .001$). Large farms were not associated with state prevalence (log odds = 1.03; 95% CI = 0.43-2.5; $P \geq .05$). When considered alone, the total number of small domestic swine farms explained the majority of the variance in PRRS prevalence in feral swine with an adjusted R^2 of 63%. Every additional 100 small farms in a state was associated with an 11% increase in state prevalence.

Discussion

Similar to our findings, in France the antibody prevalence of PRRS in feral swine was approximately 3.5%, and all positive feral swine were identified in areas with a high density and prevalence of infection in domestic swine.¹⁵ However, no antibodies to PRRSV were detected in feral swine in Spain¹⁹ or Slovenia,²⁰ which may be due to the relatively small sample sizes (78 in Spain and 178 in Slovenia) in those studies or attributed to a difference in herd structure and management.⁶

Transmission of PRRS occurs through direct contact, contaminated fomites, or aerosolized particles.^{21,22} Direct contact between domestic swine and feral swine has been documented¹¹ and suggests that there is a potential for pathogen transmission to occur via this route. PRRS is common in US domestic swine, with antibody prevalence in unvaccinated animals ranging from 20.0% to 69.6%.²³⁻²⁵ Since the antibody prevalence of PRRS virus detected in feral swine in this study was so low in comparison, and the antibody prevalence in feral swine increased with the number of domestic swine farms in the state, the risk of feral swine transmitting PRRS to domestic swine remains low as reported previously.¹² It also suggests that feral swine acquired the infection from domestic swine. However, it remains unclear if feral

Table 1: Apparent antibody prevalence with 95% confidence intervals (CI) and Bayesian estimated true prevalence with 95% credible intervals (CrI) of feral swine serum samples collected from across the United States from October 1, 2013, through September 30, 2015, and tested for exposure to porcine reproductive and respiratory syndrome with an enzyme-linked immunosorbent assay

State (n)	Apparent prevalence (95% CI)	True prevalence (95% CrI)	Pr* prevalence ≠ national
National (5506)	1.2 (0.01-1.5)	1.9 (0.3-7.2)	NA
Alabama (194)	0.5 (0.09-2.9)	2.1 (0.4-7.8)	0.05
Arizona (44)	0 (0-8.0)	1.7 (0.3-6.1)	0.14
Arkansas (323)	0 (0-1.2)	1.6 (0.3-3.8)	0.34
California (479)	1.3 (0.6-2.7)	1.5 (0.4-6.2)	0.08
Florida (584)	2.6 (1.6-4.2)	3.5 (0.4-7.4)	0.16
Georgia (320)	2.2 (1.1-4.5)	2.0 (0.4-8.2)	0.10
Hawaii (297)	3.4 (1.8-6.1)	3.5 (2.0-5.5)	0.48
Illinois (21)	0 (0-15.4)	3.3 (0.7-7.6)	0.16
Indiana (12)	0 (0-24.3)	3.2 (0.8-8.5)	0.19
Kansas (195)	0 (0-1.9)	0.9 (0.1-4.1)	0.52
Kentucky (20)	0 (0-16.1)	3.1 (0.9-8.4)	0.20
Louisiana (276)	0.7 (0.2-2.6)	2.0 (0.3-7.2)	0.08
Michigan (16)	0 (0-19.4)	4.1 (0.8-9.6)	0.30
Mississippi (256)	0.4 (0.1-2.2)	2.9 (0.6-7.9)	0.13
Missouri (114)	0 (0-3.3)	1.9 (0.2-5.5)	0.18
New Mexico (97)	0 (0-3.8)	2.5 (0.8-8.1)	0.19
New York (11)	0 (0-25.9)	1.4 (0.4-7.3)	0.05
North Carolina (245)	1.2 (0.4-3.5)	1.3 (0.3-7.0)	0.09
Ohio (72)	0 (0-5.1)	1.2 (0.2-4.9)	0.31
Oklahoma (467)	0.9 (0.3-2.2)	1.7 (0.4-7.6)	0.07
Oregon (49)	0 (0-7.3)	2.6 (0.5-6.3)	0.10
South Carolina (274)	3.3 (1.7-6.1)	1.0 (0.3-8.8)	0.22
Tennessee (125)	0 (0-3.0)	1.1 (0.2-5.8)	0.24
Texas (889)	0.9 (0.5-1.8)	2.0 (0.4-7.3)	0.05
Virginia (86)	2.3 (0.6-8.1)	1.7 (0.4-8.6)	0.15
West Virginia (40)	0 (0-8.8)	1.8 (0.3-5.7)	0.14

* Probability
NA = not applicable.

swine are important sources of virus spillback into domestic swine or for long-term maintenance of the virus, since direct contact or high densities would be required for this to occur. Given the relatively high PRRS prevalence in domestic swine, areas with high densities of feral swine or poor biosecurity (ie, feral swine access to domestic swine) may increase the likelihood of PRRS transmission between domestic and feral swine in localized areas. Small swine farms (< 100 animals) were associated with increased prevalence and may be at higher risk for

contact and transmission of PRRS and other pathogens due to poor biosecurity compared to that in commercial swine operations. Thus, we recommend additional studies to quantify the risk to both small swine farms and to large swine operations. Although feral swine populations were reported in 17 states in 1988, they now exist in at least 35 states and exceed 5 million individuals.⁴ Relative to the distribution and size of feral swine populations in the United States, our sample size was small and may have missed local areas of higher prevalence. Consequently, this study

should be considered an initial investigation into national scale PRRS prevalence. Since antibody prevalence is not equivalent to viral shedding, it is unclear whether the feral swine tested in this study were infectious at the time they were sampled. Additional surveillance in feral swine is warranted to quantify the frequency with which feral swine shed virus and to determine if areas with higher prevalence are associated with certain swine production practices such as pasture-raised swine or organic production. These practices may result in more opportunities

for pathogen transmission. Surveillance and longitudinal studies to investigate PRRS prevalence and strain diversity in areas where feral and domestic swine overlap are recommended to provide better information on transmission and the role of feral swine in the epidemiology of PRRS.

Implications

- Although feral swine may become infected with PRRSV, it is unclear if they are an important reservoir and source of spillback to domestic swine or involved in local area spread of PRRS.
- The relatively low prevalence of PRRS in feral swine combined with increased antibody prevalence in areas where domestic swine farms exist suggest that the risk of transmission from feral swine to domestic swine is low.

Acknowledgements

We thank all of the wildlife biologists and technicians who participated in collecting the samples included in this study and spending many hours trapping feral swine and preparing samples for testing. Mention of trade names or commercial products in this work is solely for the purpose of providing specific information and does not imply recommendation or endorsement by the US Department of Agriculture.

Conflict of interest

None reported.

Disclaimer

Scientific manuscripts published in the *Journal of Swine Health and Production* are peer reviewed. However, information on medications, feed, and management techniques may be specific to the research or commercial situation presented in the manuscript. It is the responsibility of the reader to use information responsibly and in accordance with the rules and regulations governing research or the practice of veterinary medicine in their country or region.

References

1. Mayer JJ, Brisbin IL. *Wild pigs in the United States: Their history, comparative morphology, and current status*. Athens, Georgia: University of Georgia Press; 2008; 313 pp.
2. Campbell TA, DeYoung RW, Wehland EM, Grassman LI, Long DB, Delgado-Acevedo J. Feral swine exposure to selected viral and bacterial pathogens in southern Texas. *J Swine Health Prod*. 2008;16:312–315.
3. Witmer GW, Sanders RB, Taft AC. Feral swine - Are they a disease threat to livestock in the United States? *Proc 10th Wildl Damage Manage Conf*; Wildlife Damage Management Working Group of the Wildlife Society, Hot Springs, Arkansas; 2003:316–325.
4. Bevins SN, Pedersen K, Lutman MW, Gidlewski T, Deliberto TJ. Consequences associated with the recent range expansion of nonnative feral swine. *Bioscience*. 2014;64:291–299.
5. Holtkamp DJ, Kliebenstein JB, Neumann E, Zimmerman JJ, Rotto H, Yoder TK, Wang C, Yeske P, Mowrer CL, Haley CA. Assessment of the economic impact of porcine reproductive and respiratory syndrome virus on United States pork producers. *J Swine Health Prod*. 2013;21:72–84.
6. Albina E. Epidemiology of porcine reproductive and respiratory syndrome (PRRS): An overview. *Vet Microbiol*. 1997;55:309–316.
7. Rossow K. Porcine reproductive and respiratory syndrome. *Vet Pathol*. 1998;35:1–20.
8. Plagemann PG. Porcine reproductive and respiratory syndrome virus: origin hypothesis. *Emerg Infect Dis*. 2003;9:903–908.
9. Saliki JT, Rodgers SJ, Eskew G. Serosurvey of selected viral and bacterial diseases in wild swine from Oklahoma. *J Wildl Dis*. 1998;34:834–838.
10. Corn JL, Cumbee JC, Barfoot R, Erickson GA. Pathogen exposure in feral swine populations geographically associated with high densities of transitional swine premises and commercial swine production. *J Wildl Dis*. 2009;45:713–721.
11. Wyckoff AC, Henke SE, Campbell TA, Hewitt DG, VerCauteren KC. Feral swine contact with domestic swine: a serologic survey and assessment of potential for disease transmission. *J Wildl Dis*. 2009;45:422–429.
12. Baroch JA, Gagnon CA, Lacouture S, Gottschalk M. Exposure of feral swine (*Sus scrofa*) in the United States to selected pathogens. *Can J Vet Res*. 2015;79:74–78.
13. Messam LLM, Branscum AJ, Collins MT, Gardner IA. Frequentist and Bayesian approaches to prevalence estimation using examples from Johnes's disease. *Anim Health Res Rev*. 2008;9:1–23.
14. Pedersen K, Miller RS, Anderson TD, Pablonia KL, Lewis JR, Mihalco RL, Gortazar C, Gidlewski T. Limited antibody evidence of exposure to *Mycobacterium bovis* in feral swine (*Sus scrofa*) in the USA. *J Wildl Dis*. 2017;53:30–36.
15. Albina E, Mesplede A, Chenut G, Le Potier MF, Bourbao G, Le Gal S, Leforban Y. A serological survey on classical swine fever (CSF), Aujeszky's disease (AD) and porcine reproductive and respiratory syndrome (PRRS) virus infections in French wild boars from 1991 to 1998. *Vet Microbiol*. 2000;77:43–57.
16. Sattler T, Wodak E, Schmoll F. Evaluation of the specificity of a commercial ELISA for detection of antibodies against porcine respiratory and reproductive syndrome virus in individual oral fluid of pigs collected in two different ways. *BMC Vet Res*. 2015;11:70.
17. Gelman A, Carlin JB, Stern HS, Rubin DB. *Bayesian data analysis*. 3rd ed. Boca Raton, Florida: CRC Press, Taylor & Francis Group; 2014; 656 pp.
18. Papke LE, Wooldridge J. Econometric methods for fractional response variables with an application to 401 (k) plan participation rates. *J Appl Econ*. 1996;11:619–632.
19. Vicente J, León-Vizcaíno L, Gortázar C, Cubero MJ, Gonzalez M, Martin-Atance P. Antibodies to selected viral and bacterial pathogens in European wild boars from southcentral Spain. *J Wildl Dis*. 2002;38:649–652.
20. Vengust G, Valencak Z, Bidovec A. A serological survey of selected pathogens in wild boar in Slovenia. *J Vet Med Series B*. 2006;53:24–27.
21. Kristensen CS, Bøtner A, Takai H, Nielsen JP, Jorsal SE. Experimental airborne transmission of PRRS virus. *Vet Microbiol*. 2004;99:197–202.
22. Done S, Paton D, White M. Porcine reproductive and respiratory syndrome (PRRS): a review, with emphasis on pathological, virological and diagnostic aspects. *Br Vet J*. 1996;152:153–174.
23. Dee SA, Bierk MD, Deen J, Molitor TW. An evaluation of test and removal for the elimination of porcine reproductive and respiratory syndrome virus from 5 swine farms. *Can J Vet Res*. 2001;65:22–27.
24. Bush EJ, Thacker EL, Swenson SL. National seroprevalence of PRRS, mycoplasma, and swine influenza virus. American Association of Swine Veterinarians. 2003;491–494. https://www.aphis.usda.gov/animal_health/nahms/swine/downloads/swine2000/Sero_PRRS.pdf.
25. Animal and Plant Health Inspection Service-Veterinary Services. PRRS Seroprevalence on U.S. Swine Operations. Fort Collins, Colorado, USA: USDA-APHIS, 2009. https://www.aphis.usda.gov/animal_health/nahms/swine/downloads/swine2006/Swine2006_is_PRRS.pdf.



Checkoff holds first Pig Welfare Symposium

The Pork Checkoff hosted the inaugural Pig Welfare Symposium (PWS) in Des Moines, Iowa, November 7 to 9. The agenda focused on general welfare concepts and how they can be applied at the farm level. After the general session, breakout sessions addressed lameness, the Common Swine Industry Audit, pain management, animal handling, euthanasia, and gestation sow housing. Highlights included defining animal welfare,

a live consumer panel, international perspectives on emerging issues, and producers sharing their on-farm experiences. In all, 260 people registered for in-person attendance and 44 registered for virtual attendance for the Pig Welfare Symposium. This included producers, academia, veterinarians, packers-processors, allied industry, and NGOs. Sixty of the attendees also each participated in one of three interactive workshops – Common

Swine Industry Audit, on-farm euthanasia, and low-stress pig handling. The PWS steering committee has met to start planning the next PWS to be held in 2019.

For more information, contact Dave Pyburn at DPyburn@pork.org or call 515-223-2634. Also, recordings of the presentations will be posted on pork.org soon.

Checkoff collaborates with China on pig welfare

The National Pork Board recently participated in a joint meeting between the UN Food and Agriculture Organization (FAO) and the China Association of the Promotion of International Agricultural Cooperation (CAPIAC). The International Cooperation Committee of Animal Welfare (ICCAW), a subgroup of the CAPIAC, focused on

animal welfare. AASV's Associate Editor for the *Journal of Swine Health and Production*, Sherrie Webb, (formerly Checkoff's director of animal welfare), presented at the conference to share the experiences with PQA Plus and the Common Swine Industry Audit as examples of a continuous improvement tool that helps ensure that animal welfare remains

top priority in a large industry. As a mutual sign of collaboration, the secretary general of the ICCAW, Mr Ayoshi, attended the Checkoff's Pig Welfare Symposium last November and presented a special pre-session discussion about China's pork industry and its welfare-related issues.

Pig Loss Working Group continues work

The Pork Checkoff's Animal Science Committee approved using some remaining 2017 research funds toward the pig loss effort. A recent request for proposals focused on sow prolapse causation factors and was distributed to a targeted audience. This resulted in one proposal that the committee funded.

The research that began in 2017 should be completed by June 2018. The welfare committee elected to contribute \$200,000 of their 2018 budget to this effort. This brings the 2018 total funding for this effort to \$1 million. Chris Hostetler has submitted a proposal to the Foundation for Food and

Agriculture Research (FFAR) to explore additional supporting funds.

For more information, contact Chris Hostetler at CHostetler@pork.org or call 515-223-2606.

Checkoff research: Surveillance changes needed to reflect the impact of on-farm antimicrobial use

The National Antimicrobial Resistance Monitoring System (NARMS) has long been used to monitor trends in antimicrobial resistance of foodborne bacteria such as *Salmonella*, *Campylobacter*, and *Escherichia coli*. However, NARMS was never designed to correlate on-farm antimicrobial use with resistance trends. Consequently, Checkoff-funded researchers such as Dr Timothy Frana of Iowa State University set out to examine the potential impact of common hog transport practices on the antimicrobial

resistance patterns of *Salmonella*, *Campylobacter*, and *E coli* post slaughter. They also looked for any differences in the bacterial populations on the basis of prevalence, serotype, or pattern changes. Researchers collected fecal samples from truckloads of 150 or more pigs upon arriving at the packing plant and collected cecum samples post slaughter. They then tested *Salmonella*, *Campylobacter*, and *E coli* isolates for resistance to certain antimicrobials. Of the 1163 isolates collected, 898 (77%) were resistant

to at least one antimicrobial tested. However, the samples collected post slaughter did not reflect the resistance patterns identified when pigs arrived at the plant, and therefore are not useful for monitoring on-farm antimicrobial resistance.

For more information, contact Steve Larsen at SLarsen@pork.org or call 515-223-2754. You may also search for the related research study on pork.org.



Deliberately[™] Different.

Accelerated Hydrogen Peroxide[®]
Disinfectants for Infection Control
& Biosecurity



Outbreaks eroding your bottom line? It's time for an **INTERvention**[®]

Accelerated Hydrogen Peroxide[®] (AHP[®]) disinfectants are a *Deliberately Different* way to protect you against the devastating financial impact of an outbreak. Intervention[™] was designed to break the chain of infection before the outbreak starts while remaining less toxic (requiring no PPE at in use solutions) and easy to handle (reducing labour costs). Using Intervention[™] improves animal and human health by reducing the risk of exposure to both harsh chemicals and deadly pathogens.

That's why we are not just *different* from what you're currently using, we are *Deliberately Different*[™].



ViroxAnimalHealth.com

Contact Virox Animal Health for product distribution information.



Member of the
AASV Industry Support Council



Patented



Webb accepts new role with AASV

The American Association of Swine Veterinarians (AASV) welcomes Ms Sherrie Webb as associate editor of the *Journal of Swine Health and Production* (JSHAP). In her new role, Webb will join the current JSHAP staff tasked with producing the association's bi-monthly journal. Webb accepted the position currently held by Dr Judi Bell, who has announced her retirement after 17 years with the journal.

Webb will be responsible for editing and proofreading scientific articles submitted for publication in JSHAP. She will work closely with the authors to address comments from reviewers and the executive editor to ensure the articles conform to the journal's standards for grammar and style. In addition to her work with JSHAP, Webb will also utilize her expertise in swine well-being to advise on animal welfare issues and aid in the development of welfare outreach and education opportunities for AASV.

"We are thrilled to be adding Sherrie to our staff at AASV. Her scientific credentials, knowledge, and experience provide a tremendous opportunity for AASV, both in her editorial role and her work in the area of swine welfare," noted Dr Tom Burkgren, AASV executive director.

Webb received her Master's degree in Animal Science from the University of Illinois in 2006. Prior to joining AASV, Webb was Director of Animal Welfare, Science & Technology for the National Pork Board where she oversaw the Pork Checkoff animal welfare program. In that role, she worked with veterinarians, producers, and other segments of the pork chain to identify welfare issues concerning the swine industry and worked collaboratively to provide solutions to these issues.

Sherrie will begin her new responsibilities on January 8, 2018. Please join us in welcoming Sherrie to AASV and JSHAP.



Burkgren announces retirement

At the AASV fall board meeting, Dr Tom Burkgren communicated his desire to retire from his role as executive director of the American Association of Swine Veterinarians. Dr Burkgren has served our organization very capably for 24 years, 21 years in the role of executive director. His dedication, professionalism, and leadership will be missed.

The AASV and Dr Burkgren have agreed to a contract extension that allows the association approximately a year to identify a replacement while Tom continues his current duties and responsibilities. This extension also allows for an overlap in employment with the successful applicant to accommodate a smooth transition.

The board has authorized the formation of a search committee to begin this process. The committee membership consists of Drs Scanlon Daniels, Bill Hollis, Deb Murray, Megan Potter, Max Rodibaugh, and Pete Thomas. The committee is in the process of evaluating third-party facilitators who may be of assistance in the search process. The search committee and board understand the importance of conducting this process with integrity, diligence, confidentiality, and transparency.

We will strive to keep you informed of updates on the process and timeline as they develop. Please join me in thanking Tom for his service to our membership and profession.

Scanlon Daniels, DVM
Chair, Search Committee



University of Minnesota College of Veterinary Medicine establishes fund in memory of Dr Bob Morrison

Throughout his distinguished professional career, Dr Bob Morrison was an integral part of the swine community as a practitioner, professor, swine producer, researcher, veterinarian, mentor, and valued colleague and friend to many. Bob was passionate about helping producers and veterinarians and led educational programs that built human capacity that transformed our industry. With this spirit in mind, the University of Minnesota College of Veterinary Medicine has established the Morrison Fund to carry forward Bob's impact. The university-sponsored initiative focuses on outreach, integrates research and industry, working with swine practitioners and farmers, and contributes to the success of the swine industry. Contributions to the university will support a broad community of DVM students, graduate students, practitioners, and researchers to lead the industry in important and sound study and knowledge-based advances in health and production.

Bob received his DVM from the Western College of Veterinary Medicine, University of Saskatchewan in 1979 followed by his PhD and MBA from the University of Minnesota in 1984 and 1994, respectively. Bob started his tenure as faculty at the University of Minnesota in 1986. Bob cherished his time teaching and mentoring veterinary and graduate students for the duration of his life. He was passionate about the swine industry and helping veterinarians and producers address their challenges. Bob served as AASV president and he was instrumental in establishing and

leading the *Journal of Swine Health and Production* in the early days. Bob was active in various industry committees and at the AASV, and his impact was felt at many levels. Bob coordinated two internationally recognized conferences, the Leman Swine Conference and the Leman China Conference, and in 2016 Bob was recognized with the prestigious Master of Pork Industry Award by the *National Hog Farmer* for his dedication to swine producers.

His work at the University of Minnesota helped lead the industry in the control of important diseases of swine from pseudorabies to PRRS, PED, and beyond. Bob's drive and passion invigorated everyone he touched and was evident in all aspects of his life and work. He ably combined grace, sincerity, kindness, humor, and a great vitality. He had a boundless sense of curiosity, with which he guided us to seek out answers with him. He often mentioned that if there was an attribute he wanted to be remembered for, it was "integrity." We surely will remember Bob's integrity. Bob had a deep impact on every person who worked with him. Bob's unique talent for creating relationships that advanced the swine industry culminated in the creation of the Swine Health Monitoring Project (SHMP) (now called the Morrison Swine Health Monitoring Program), an initiative that Bob conducted with great pride. The MSHMP has led the swine communities to share data to more effectively manage and control diseases, and provides a foundation to more ably address future challenges.



Bob always sought to do meaningful work that would yield value for producers, veterinarians, researchers, and consumers.

Through this initiative, the University of Minnesota College of Veterinary Medicine strives to carry forward Bob's legacy by continuing his efforts to help producers and veterinarians and build human capacity that transforms our industry. For more information about the Morrison Fund please contact Mindy Means at mkmeans@umn.edu or Tel: 612-626-5482 or Cell: 208-310-3562; <https://making-a-gift.umn.edu/donate/fund-contact-info.html?&fundCode=21780>.

Montse Torremorell, DVM, PhD
University of Minnesota



AASV FOUNDATION NEWS

Challenges, challenges!

At our last annual meeting in Denver, during the Past President's Breakfast, several of us were visiting about how important the AASV organization and fellow swine practitioners have been to all of our careers. In no small way, our organization has been instrumental in various aspects of all our careers. We all agreed that the same opportunities presented by membership in AASV must be continued for future generations. Out of that discussion sprang the idea to challenge our past and present officers of AASV and the foundation to "recruit" at least three current members to become new Leman, Heritage, or Legacy fellows.

Just a couple of years ago, Dr Daryl Olsen challenged us to grow the foundation-endowed funds to \$2 million in time for AASV's 50th anniversary in 2019. To accomplish this challenging goal, everyone will

need to help. The AASV members always step up and this will be no exception! If each past and current member of the executive and foundation boards accept our challenge to recruit three new fellows to the Leman, Heritage, or Legacy levels, we are certain to meet the challenge.

"Dr Daryl Olsen challenged us to grow the foundation-endowed funds to \$2 million in time for AASV's 50th anniversary in 2019."

So, when someone comes asking you to support the foundation, remember how much AASV has done for you and help pass on the heritage and legacy from which you have benefited since you first decided to accept the challenge of becoming a pig vet!



The past presidents have all the information to answer your questions and all the materials needed to sign you up! I challenge you!

John Waddell, DVM
Chairman, AASV Foundation



EVERYBODY BID!

The AASV Foundation Auction Committee is counting on AASV members' shared sense of purpose to "SEAL the Deal" for another successful fundraising auction in San Diego this March. The annual auction proceeds are a major source of revenue to support ongoing foundation programs, including scholarships, swine research grants, travel stipends for veterinary students, swine externship grants, tuition grants at the Swine Medicine Education Center, ACAW board certification efforts, and more.

YOU can help "SEAL the Deal" by participating in the auction! Here's how:

Make sure to check out the items up for bid at www.aasv.org/foundation. While you're there, bookmark the mobile bidding Web site on your phone or tablet, and start bidding! If you're not ready to bid, you can "follow" items that you're interested in – but go ahead, be brave and enter your "max" bid! The app will bid incrementally for you, without revealing your limit to others. You'll receive notifications to let you know if you're winning or losing your coveted items.

It's easy – and fun! And, most importantly, you'll be supporting the foundation with every dollar you spend, since all of the auction items have been donated.

The auction items will be on display in San Diego on auction day, Monday, March 5. Remember, you don't need to be in San Diego to participate. With mobile bidding, you can bid from anywhere! It will be "all-in, all-done" when the silent auction closes at 7:00 PM Pacific Standard Time, followed by the live auction, which will be held after the Awards Reception.

Foundation news continued on page 51

NEW
for SRD

AIVLOSIN®

(tylvalosin)

Disease control at
both ends with
outstanding results.

SRD

swine respiratory disease

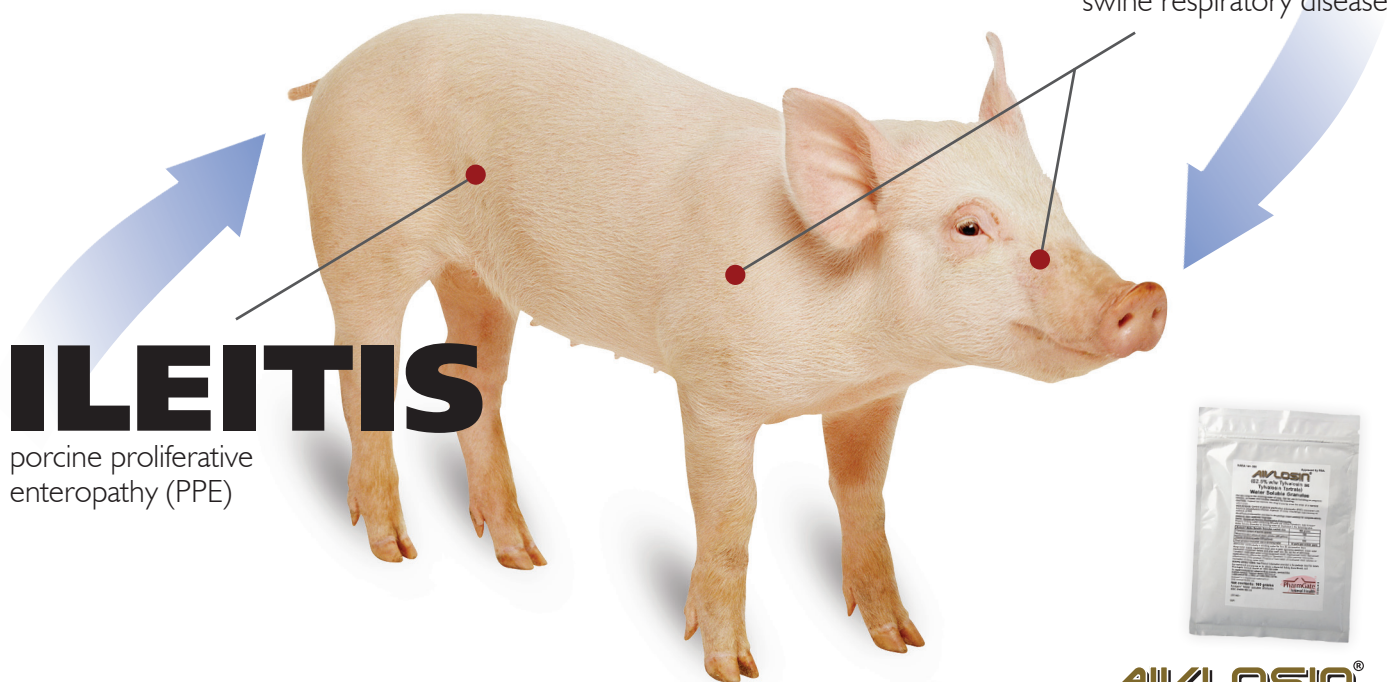

ILEITIS

porcine proliferative
enteropathy (PPE)

AIVLOSIN®
Water Soluble Granules

AIVLOSIN® is your powerful new tool for cost-effective control of **both** SRD and ileitis with **no** withdrawal period. Tylvalosin, the active ingredient of AIVLOSIN, is a potent new macrolide antibiotic that provides rapid and effective control of SRD and ileitis. AIVLOSIN can be conveniently administered in drinking water, offering you flexibility and outstanding results when targeting SRD or ileitis in just a single pen or whole-house outbreaks. Ask your veterinarian about trying AIVLOSIN in your herd.

AIVLOSIN®

Important Safety Information: Available under prescription only. AIVLOSIN is indicated for the control of swine respiratory disease (SRD) associated with *Bordetella bronchiseptica*, *Haemophilus parasuis*, *Pasteurella multocida*, and *Streptococcus suis*, or PPE caused by *Lawsonia intracellularis*, in groups of swine in a house experiencing an outbreak of either disease. For use only in the drinking water of pigs. Not for use in lactating or pregnant females, or males and females intended for breeding. People with known hypersensitivity to tylvalosin tartrate should avoid contact with this product. When used in accordance with label directions, no withdrawal period is required before slaughter for human consumption.

14040 Industrial Road, Omaha, NE 68144
800.832.8303 www.pharmgateAH.com
AIVLOSIN® is a registered trademark of ECO
Animal Health Ltd., London, U.K. 1060-0717
©2017 Pharmgate Animal Health LLC.

PharmGate
Animal Health

NADA 141-336

Approved by FDA.

AIVLOSIN®

(62.5% w/w Tylvalosin as
Tylvalosin Tartrate)

Water Soluble Granules

Use only as directed.

For use only in the drinking water of pigs.

Not for use in lactating or pregnant females, or
males and females intended for breeding.

CAUTION:

Federal law restricts this drug to use by or on the order
of a licensed veterinarian.

PRODUCT DESCRIPTION:

Aivosin® (tylvalosin tartrate) Water Soluble Granules is
a water soluble granular powder for oral use by
administration in the drinking water. Each gram of
Aivosin® Water Soluble Granules contains 0.625 grams
of tylvalosin as tylvalosin tartrate.

INDICATIONS:

Swine:

Control of porcine proliferative enteropathy (PPE)
associated with *Lawsonia intracellularis* infection in
groups of swine in buildings experiencing an outbreak
of PPE.

Control of swine respiratory disease (SRD) associated
with *Bordetella bronchiseptica*, *Haemophilus parasuis*,
Pasteurella multocida, and *Streptococcus suis* in groups
of swine in buildings experiencing an outbreak of SRD.

DOSAGE AND ADMINISTRATION:

Swine:

Prepare drinking water medicated with 50 parts per
million tylvalosin as shown in the following table.

Aivosin® Water Soluble Granules sachet size	40 grams	160 grams	400 grams
Tylvalosin content of sachet (grams)	25	100	250
Recommended volume of stock solution (US gallons)	1	4	10
Volume of drinking water (US gallons)	132	528	1320
Final tylvalosin inclusion rate in drinking water	50 parts per million (ppm)		

Administer continuously in drinking water for five (5)
consecutive days.

WARNINGS:

WITHDRAWAL PERIOD:

When used in accordance with label directions, no
withdrawal period is required before slaughter for human
consumption.

ANTIBACTERIAL WARNINGS:

Use of antibacterial drugs in the absence of a
susceptible bacterial infection is unlikely to provide
benefit to treated animals and may increase the
development of drug-resistant pathogenic bacteria.

USER SAFETY WARNINGS:

NOT FOR USE IN HUMANS.

KEEP OUT OF REACH OF CHILDREN.

May cause skin irritation. Tylvalosin tartrate has been
shown to cause hypersensitivity reactions in laboratory
animals.

People with known hypersensitivity to tylvalosin tartrate
should avoid contact with this product. In case of
accidental ingestion, seek medical advice.

When handling Aivosin® Water Soluble Granules and
preparing medicated drinking water, avoid direct contact
with the eyes and skin. Wear a dust mask, coveralls and
impervious gloves when mixing and handling this
product. Eye protection is recommended. In case of
accidental eye exposure, wash eyes immediately with
water and seek medical attention. If wearing contact
lenses, immediately rinse the eyes first, then remove
contact lenses and continue to rinse the eyes thoroughly
and seek medical attention. Avoid eating, chewing gum
and smoking during handling. Wash contaminated skin.
The Safety Data Sheet contains more detailed
occupational safety information.

PRECAUTIONS:

Not for use in lactating or pregnant females, or males
and females intended for breeding. The effects of
tylvalosin on swine reproductive performance,
pregnancy, and lactation have not been determined. The
safety and efficacy of this formulation in species other
than swine have not been determined.

ADVERSE REACTIONS IN ANIMALS:

No adverse reactions related to the drug were observed
during clinical or target animal safety trials.

ANIMAL SAFETY: Swine:

Margin of safety: Aivosin® Water Soluble Granules
given orally in drinking water at 0, 50, 150 and 250 ppm
tylvalosin (0, 1X, 3X and 5X the labeled dose,
respectively) to 8 healthy pigs per treatment group over
15 days (3X the labeled duration) did not result in
drug-induced clinical signs, gross pathologic lesions,
histopathologic lesions or clinically-relevant clinical
pathology abnormalities.

For technical assistance or to obtain a Safety Data
Sheet, call PharmGate Animal Health at

1-800-380-6099. To report suspected adverse drug
events, contact the ASPCA Animal Product Safety
Service at 1-800-345-4735 or

FDA at 1-888-FDA-VETS.

Aivosin® is a registered
trademark of ECO Animal Health Ltd.



Foundation earmarks \$60,000 for research: Proposals due January 16

As part of its mission to fund research
with direct application to the profession,
the American Association of Swine Veteri-
narians Foundation is accepting research
proposals to be considered for funding in
2018. Proposals are **due January 16, 2018**,
and may request a maximum of \$30,000
(US\$) per project. A maximum of \$60,000
will be awarded across two or more projects.
The announcement of projects selected for
funding will take place at the AASV Foun-
dation Luncheon in San Diego, California,
on Sunday, March 4, 2018 (awardees will be
notified in advance).

Proposed research should fit one of the five
action areas stated in the AASV Foundation
mission statement (see sidebar).

The instructions for submitting proposals
are available on the AASV Foundation
Web site at [https://www.aasv.org/
foundation/2018/research.php](https://www.aasv.org/foundation/2018/research.php).
Proposals may be submitted by mail or
e-mail (preferred).

A panel of AASV members will evaluate and
select proposals for funding on the basis of
the following scoring system:

- Potential benefit to swine veterinarians/
swine industry (40 points)
- Probability of success within timeline
(35 points)
- Scientific/investigative quality
(15 points)
- Budget justification (5 points)
- Originality (5 points)

For more information, or to submit a
proposal:

AASV Foundation, 830 26th Street, Perry,
IA 50220-2328; Tel: 515-465-5255;

E-mail: aasv@aasv.org.

AASV Foundation Mission Statement

The mission of the AASV Foundation
is to empower swine veterinarians to
achieve a higher level of personal and
professional effectiveness by

- Enhancing the image of the swine
veterinary profession,
- Supporting the development
and scholarship of students and
veterinarians interested in the
swine industry,
- Addressing long-range issues of
the profession,
- Supporting faculty and promoting
excellence in the teaching of swine
health and production, and
- Funding research with direct
application to the profession.

Hogg Scholarship applications due February 1

The American Association of Swine Veterinarians Foundation is pleased to offer the Hogg Scholarship, established to honor the memory of longtime AASV member and swine industry leader Dr Alex Hogg. Applications for the \$10,000 scholarship will be accepted until February 1, 2018, and the scholarship recipient will be announced on Sunday, March 4, during the Foundation Luncheon at the AASV 2018 Annual Meeting in San Diego.

The intent of the scholarship is to assist a swine veterinarian in his or her efforts to return to school for graduate education (resulting in a master's degree or higher) in an academic field of study related to swine health and production.

Dr Alex Hogg's career serves as the ideal model for successful applicants. After 20 years in mixed-animal practice, Dr Hogg pursued a master's degree in veterinary pathology. He subsequently became Nebraska's

swine extension veterinarian and a professor at the University of Nebraska. Upon "retirement," Dr Hogg capped off his career with his work for MVP Laboratories. Always an enthusiastic learner, at age 75 he graduated from the Executive Veterinary Program offered at the University of Illinois.

The scholarship application requirements are outlined below and on the AASV Web site at <https://www.aasv.org/foundation/hoggscholarship.htm>.

Hogg Scholarship application requirements

An applicant for the Hogg Scholarship shall have

1. Five or more years of experience as a swine veterinarian, either in a private practice or in an integrated production setting, and

2. Five or more years of continuous membership in the American Association of Swine Veterinarians.

Applicants are required to submit the following for consideration as a Hogg Scholar:

1. Current curriculum vitae,
2. Letter of intent detailing his or her plans for graduate education and future plans for participation and employment within the swine industry,
3. Two letters of reference from AASV members attesting to the applicant's qualifications to be a Hogg Scholar.

Applications and requests for information may be addressed to AASV Foundation, 830 26th Street, Perry, IA 50220-2328; Tel: 515-465-5255; E-mail: aasv@aasv.org.



GLOBAL KNOWLEDGE: *Individual Application*



49th AASV Annual Meeting
March 3-6, 2018 • San Diego, California

Howard Dunne Memorial Lecture
Bill DuBois

Alex Hogg Memorial Lecture
Rodger Main

Register now at <http://ecom.aasv.org/annmtg>



Autogenous Vaccine Solutions

Addressing your herd's disease challenges by:

Identifying and isolating the disease causing pathogens

Reliable, accurate and timely response from our specialized diagnostic lab

Phibro's Tailor-Made[®] Vaccines

*High quality, safe, multivalent autogenous vaccines**

Include MVP Adjuvants[®] — developed by professionals who understand vaccines

*Potency and efficacy of autogenous biologics have not been established

To learn more, visit www.phibropro.com

MJPPRS[®] | Emulsibac[®] - APP | Tailor-Made[®] Vaccines

VFD audits

Here's the scenario: it's 8:15 AM on a Monday morning. You've just walked into the back door of the clinic clutching the remnants of your second cup of coffee. As you're checking the duty calendar, the receptionist calls back on the clinic-wide intercom, "Hey Dr Whyme, can you come up front? There's a guy here with a badge. He says he's from the FDA and wants to check your VFDs."

As you walk to the front of the clinic, you notice all the half-eaten donuts and steaming cups of coffee sitting on the desks of the now empty offices of your veterinary partners. Desk chairs still twirling. As you continue your march of dread you're at least comforted by something you recently read in the AASV e-Letter's Doc Tales: "If you have to eat a frog first thing in the morning, you at least get to go through the rest of your day knowing the worst is behind you."

Finally, the second longest walk of your life (the first being leaving your anatomy final wondering why in the hell a swine vet needs to be able to identify and name the pudendal artery when all you really need to know is, if ever faced with the option, don't cut it) ends with you standing face to face with someone you've never seen in your life and, yep, he's holding a badge. He thrusts out his hand (the one without the badge) and introduces himself as FDA Compliance Officer I. M. Heretohelp.

Officer Heretohelp hands you a copy of a Veterinary Feed Directive (VFD) form

containing your signature and explains that he is here to conduct an unannounced "random VFD audit." He indicates that he is coming from the local feed mill and is just following up to determine if all parties are following the proper procedure for issuing a VFD, manufacturing and distributing the VFD feed, and feeding the VFD feed. He calms your nerves slightly by assuring you that this visit is "educational" in nature to determine whether or not all parties understand and are complying with the new VFD regulations. He's quick to note, however, that although the FDA wants to make sure everyone is comfortable with the new regulation, the agency will soon be transitioning to full-on compliance investigations. Then he asks to see your copy of this VFD.

"The FDA continues to conduct training and educational audits of all parties subject to the VFD regulation (veterinarian, feed mill-distributor, and producer) to evaluate compliance."

You escort the investigator to your office where you turn on your computer and make chit-chat while it boots up to a picture of the two cutest grandkids in the world dressed up as a llama and a sheep (you still can't tell which is which but that's beside the point). The investigator turns down your offer of a cup of coffee, stating that caffeine tends to "make him trigger happy." You assume it's a joke but don't bother mentioning you also have decaf.

As you log into your GlobalVetLink (GVL) account, you explain to Mr Heretohelp that this VFD was issued to pigs on a farm managed by your clinic, so you are actually the veterinarian and the producer in this case. After spending a few minutes explaining how that works, you provide the investigator with two copies of the VFD from your GVL account – the veterinarian's copy and the producer's copy. He examines both copies and compares them to the VFD and feed delivery records he obtained from the feed mill. Once satisfied that the VFD

contains all the necessary information, is valid, and that the feed manufactured and delivered complies with what was requested on the VFD, Officer Heretohelp thanks you for your time and offers his appreciation for your efforts to comply with the regulation.

At 10:15 AM, you're finally standing on the doorstep to your clinic waving goodbye to the inspector, satisfied that you've done a good job and all the work your clinic put into ensuring VFD compliance has paid off. With a smile on your face and a spring you haven't had in your step since your last colonoscopy, you walk back down the hall to start your day. Amazingly, you notice that all of your partners have miraculously found their way back to their offices. Shaking your head, you grab your coffee mug and walk into the break room only to find an empty coffee pot and no donuts. Heads are going to roll!

This has been a realistic, although admittedly somewhat stylized, description of a typical FDA VFD inspection as has been recounted to me by a number of our AASV members. The FDA continues to conduct training and educational audits of all parties subject to the VFD regulation (veterinarian, feed mill-distributor, and producer) to evaluate compliance. In discussions with FDA, it has been reported to us that compliance among swine veterinarians has been very good, with no major or systemic compliance issues. If you have questions regarding the VFD, we have a number of resources available on the AASV Web site (<https://www.aasv.org/aasv%20website/Resources/Antimicrobial%20Use/VFD.php>) or you can submit your questions directly to FDA at AskCVM@fda.hhs.gov.

Harry Snelson, DVM
Director of Communications



INTRODUCING



THE BIRTH OF A NEW GENERATION IN SWINE PROTECTION

Protect your performance potential by
vaccinating pigs against influenza A
virus in swine (IAV-S), as early as day one.

Introducing Ingelvac Provenza™

- Ingelvac Provenza™ protects against multiple IAV-S strains¹
- Decreases nasal shedding, which reduces transmission in a population¹
- Live attenuated influenza vaccine (LAIV) breaks through maternal antibodies to stimulate immunity²
- Provides protection before pigs are most vulnerable (eg, commingling, weaning)³
- Intranasal administration provides protection at the site of natural IAV-S infection^{4,5}



For more information
on Ingelvac Provenza™,
ask your veterinarian or
visit IngelvacProvenza.com.

References: 1. BIAH studies #2013200, 2013232, and 2014001 published on <http://productdata.aphis.usda.gov>. 2. Genzow M, Goodell C, Kaiser TJ, Johnson W, Eichmeyer M. Live-attenuated influenza virus vaccine reduces virus shedding of newborn piglets in the presence of maternal antibody. *Influenza Other Respir Viruses*. In review [submission IRV-2017-172]. 3. Alvarez J, Sarradell J, Kerkaert B, et al. Association of the presence of influenza A virus and porcine reproductive and respiratory syndrome virus in sow farms with post-weaning mortality. *Prev Vet Med*. 2015;121:240–245. 4. Vincent AL, Ma W, Lager KM, et al. Efficacy of intranasal administration of a truncated NS1 modified live influenza virus vaccine in swine. *Vaccine*. 2007;25:7999–8009. 5. Janke BH. Influenza A virus infections in swine: pathogenesis and diagnosis. *Vet Pathol*. 2014;51:410–426.



START HEALTHY. END STRONG.

Ingelvac Provenza is a trademark of Boehringer Ingelheim Vetmedica GmbH.
© 2017 Boehringer Ingelheim Vetmedica, Inc. POR-0154-PRO0317 17301

VICE-PRESIDENTIAL CANDIDATE

Jeff Harker

I am very honored and humbled to be nominated for AASV Vice President. The AASV and its members have been an integral part of my life and practice for as long as I can remember. Each year after attending the annual convention I am inspired to improve by working smarter and harder as a swine veterinarian.

I grew up on a diversified livestock and grain farm in south central Indiana. My father built one of the first confinement swine barns in our community in 1980 when I was 10 years old. That was the year of my first interaction with an AASV member. Dr Larry Rueff visited our farm to diagnose and treat colibacillosis. That was also my first exposure to population medicine when two of the piglets were sacrificed for the benefit of the herd. It was about that time that I decided to become a veterinarian, and I was accepted into veterinary school at Purdue University in 1990. Our farm was originally a specific pathogen free (SPF) farm, so biosecurity was something I was exposed to at an early age. I met another AASV member, Dr Mike Lemmon, when he did our SPF farm inspections while I was still in high school.

My wife Traci and I have four children, Kathleen, Sarah, Matthew, and Amelia, currently ranging in age from 12 to 24. We also have a 3-year-old granddaughter. We raise sheep for the kids to show in 4-H on our small "hobby farm." We have a sizeable garden and 18 fruit trees, so we enjoy fresh fruit and vegetables all summer.

After graduating veterinary school in 1994, I joined Dr Max Rodibaugh at Swine Health Services as an associate veterinarian and then became a partner in 2001. In 2016 we joined AMVC as a satellite clinic. Our practice is dedicated to swine, and we serve a very diverse swine clientele. Our clients range from

small show-pig herds to contract growers in integrated production. The bulk of our clients are independent family farms, and these have provided many good learning experiences over my career.

I have been involved in many organizations in my lifetime, including 4-H club president and FFA chapter president. I also received the American Farmer Degree from the FFA. I served 7 years on the Indiana Pork Producers Board of Directors and was president in 2008. I am currently serving my last of 6 years as AASV district 4 director. Also for the past 6 years I have been the AASV's delegate to the AVMA House of Delegates. This interaction with AVMA is extremely important to the AASV so that we can advocate for the swine industry to the 80,000 AVMA members.

My current service on the AASV Board of Directors has helped me experience what it takes to run the AASV. This experience has prepared me to serve as vice president. My experience serving on the AASV Annual Meeting Planning Committee and planning the Indiana State Veterinary Group meeting for many years will help me to chair the planning committee. Education of our members is the primary purpose of AASV, as indicated by the recent update to the AASV's mission statement, and I intend to further that purpose.

The AASV has a very strong connection with the National Pork Board and National Pork Producers Council. I believe that I can continue to strengthen this bond due to my experience and participation in both of these organizations. One of the important jobs of AASV leadership is to serve as a spokesperson for AASV and the pork industry. I have been involved with the Operation Main Street program since it began several years



ago. I have spoken to many consumer groups about how pork is produced. Effective communication with the media is something we all must continue to do and improve upon in order to show the public that we are deserving of their trust as guardians of their food supply.

When I was involved with AASV as a veterinary student there were not many organized programs for students; however, I still felt welcome at the annual meeting. The AASV's current student programming is excellent and very encouraging for the future of swine veterinary practice. Adapting to students' changing needs will be important to keep the excellent tradition of welcoming them to the AASV before graduation.

The AASV is a very strong organization built by excellent leaders in the past. I plan to continue that legacy and serve this organization to the best of my ability.



AUTHOR GUIDELINES

Guidelines for authors submitting manuscripts

Prepare the manuscript in Word using Times New Roman 12-point font, double-spaced throughout. Submit manuscripts to the Publications Manager.

Please include:

- An electronic copy of your manuscript, with pages and lines numbered continuously;
- Files of all figures and tables;
- For all authors, names (first, middle initial, last), affiliations, and academic degrees beyond bachelor's level; and
- For the corresponding author, complete mailing address, telephone number, fax number, and e-mail address (please indicate whether you wish the e-mail address published).

Unless given alternate instructions, we will correspond with the first author, who will also receive reader inquiries and requests for reprints.

We will have your summary professionally translated into French and Spanish.

Editorial office

Karen Richardson, Publications Manager, *Journal of Swine Health and Production*; Tel: 519-856-2089; E-mail: jshap@aaasv.org.

Animal care

For experiments performed in research facilities or on commercial farms, include a statement at the beginning of the materials and methods indicating that the studies were reviewed and approved by the institutional animal care and use committee (or equivalent). For case reports and studies performed under field conditions in which animals are not manipulated beyond what would be required for diagnostic purposes, it must be clear that housing was adequate and that the animals were humanely cared for.

Permissions

If you are using copyrighted material, you must advise the editors of this when you submit your manuscript. You are responsible for securing permission to use copyrighted art or text, including the payment of fees.

Copyright transfer

When a manuscript is submitted to the *Journal of Swine Health and Production*, a pre-review copyright agreement and financial disclosure statement must be signed by all authors. It is the responsibility of the corresponding author to secure these signatures. This form is available from the Publications Manager. Submit signed copies to Karen Richardson. When your manuscript is accepted for publication, you will be required to transfer copyright to the American Association of Swine Veterinarians, with the exceptions of United States government employees whose work is in the public domain, and portions of manuscripts used by permission of another copyright holder.

Prior publication

We do not republish materials previously published in refereed journals. Sections of theses and extension publications that may be of particular value to our readership will be considered. Prior publication of an abstract only (for example, in a proceedings book) is generally acceptable.

Types of articles

The *Journal of Swine Health and Production* publishes the following types of peer-reviewed manuscripts:

- Original research
- Brief communication
- Case report
- Case study
- Literature review
- Production tool
- Peer-reviewed commentary
- Peer-reviewed diagnostic notes
- Peer-reviewed practice tip

Reference format

Authors are responsible for the accuracy of their references. References must be cited in the text using consecutive superscript numbers and listed at the end of the text in numerical order. Non-refereed references are marked with an asterisk to the left of the reference number. Only personal communications may remain in the text in parentheses. Refer to recent issues of the *Journal of Swine Health and Production* for examples of formatting for specific types of references.

Figures and tables

- Tables must be prepared using the table function in Word.
- Place the figure legends and the set of tables after the reference list in the manuscript.
- Do not paste figures into the word-processing document containing the text of the manuscript. Submit them separately, eg, submit figures created in Excel as Excel files, and submit figures created in other programs as .eps files (ie, save as .eps files from within the program that created the figures).
- Make reference in the text to all figures and tables, citing them in consecutive order.
- Provide us with numerical data for all figures, including SD or SE for means.
- Supply brief but complete titles for tables and legends for figures. Explain in footnotes abbreviations used in tables, using symbols to identify footnotes.
- For *P* values reported in a table or figure, provide the name of the statistical method used (eg, *t* test, ANOVA), not the name of the software.
- Submit photographs as individual high-resolution .jpeg images or in .tif files.

Measurements

The *Journal of Swine Health and Production* adheres, with a few exceptions, to the style of the American Medical Association.¹ A conversion chart is included at the end of the author guidelines document on the Web site at <http://www.aaasv.org/shap/guidelines.pdf>. Please see the Web version of author guidelines for full details on journal requirements for submitted manuscripts.

Reference

1. Iverson C, Christiansen S, Flanagan A, JAMA and Archives Journals Staff, eds. *AMA Manual of Style: A Guide for Authors and Editors*. 10th ed. New York, New York: Oxford University Press. 2007.



UPCOMING MEETINGS

2018 Pig-Group Ski Seminar

February 7-9, 2018 (Wed-Fri)
Copper Mountain, Colorado
866-837-2996 (Group Reservation Code 3658)

For more information:
Lori Yeske, Pig Group
Tel: 507-381-1647
E-mail: pyeske@swinevetcenter.com
Web: <http://www.pigski.com>

American Association of Swine Veterinarians 49th Annual Meeting

March 3-6, 2018 (Sat-Tue)
Manchester Grand Hyatt, San Diego, California

For more information:
American Association of Swine Veterinarians
830 26th Street, Perry, IA 50220-2328
Tel: 515-465-5255
E-mail: aasv@aasv.org
Web: <http://www.aasv.org/annmtg>

10th European Symposium of Porcine Health Management (ESPHM)

May 9-11, 2018 (Wed-Fri)
Barcelona, Spain

For more information:
Joaquim Segalés:
E-mail: joaquim.segales@irta.cat
Web: <http://www.esphm2018.org>
Maria Sanmiguel:
E-mail: msanmiguel@pacifico-meetings.com

6th International Symposium on Animal Mortality Management

June 3-7, 2018 (Sun-Thu)
Embassy Suites, Amarillo, Texas

For more information:
Web: <http://animalmortmgmt.org/>

World Pork Expo

June 6-8, 2018 (Wed-Fri)
Iowa State Fairgrounds, Des Moines, Iowa
Hosted by the National Pork Producers Council

For more information:
Web: <http://worldpork.org>

25th International Pig Veterinary Society Congress

June 11-14, 2018 (Mon-Thu)
Chongqing, China

For more information:
Web: <http://www.ipvs2018.net/>



AASV Industry Support Council

The JSHAP is made possible by the generous support of the following Industry Support Council members:

 Boehringer Ingelheim	 Elanco [™]	 MERCK Animal Health
 NEWPORT LABORATORIES	 Norbrook [®]	PHARMACOSMOS Committed to Quality
 PharmGate Animal Health	 Phibro ANIMAL HEALTH CORPORATION [™]	 provimi [®]
Tonistry	 VIROX ANIMAL HEALTH	zoetis [™]



Photo Corner

Baby pig finds a place to rest

Photo courtesy of Dr John Waddell

AASV Resources online at <https://www.aasv.org>